

Products Affected:

CTI# 5000, 5001, 5060, 5061, 5099 AutoYoke

Overview:

A change has been made to the AutoYoke regarding the Tilt Motor Mount and Pan Motor Mount.

Details:

CTI has improved the Tilt and Pan motor mounts in the AutoYoke. If you have an AutoYoke with a Serial # prior to 5000-1465, or 5001-2001¹ and replace your motor, the following notes apply.

A new replacement pan or tilt motor may require a new motor mount and encoder sensor mount. If you are unsure which design your AutoYoke currently has, measure the diameter of the encoder disk used for either the tilt or pan motor. The encoder disk is the thin metal disk with perforations around the edge visible in Figure 2. If the diameter measures 2.81 inches, it is the newer style and you can order individual parts. If it is 2.44 inches, it is the older style and you will have to order an upgrade kit which includes the motor, mount, sensors, bearing and comes fully assembled.

The new tilt motor mount is shown in Figure 1. It will mount into any yoke with the same 4 nuts and washers, and is tensioned in the same way using the same hardware.

The new pan motor mount looks like the pictured in Figure 2. It will also mount into any yoke with the same mounting hardware and tensioning hardware.

Note: As you re-connect the encoder sensor cables, swap their positions. If this is not done, the unit will fail to home itself upon powering up.

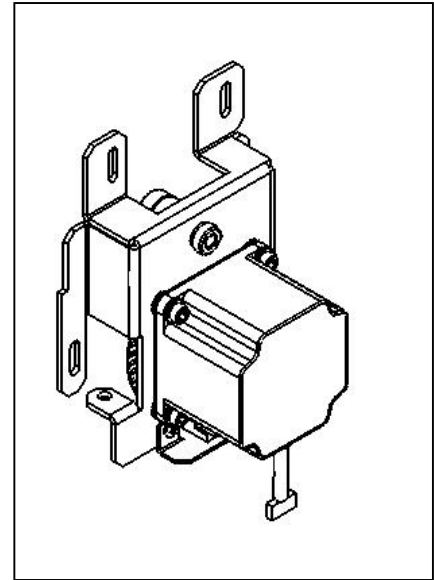

Figure 1: New Tilt Motor Mount

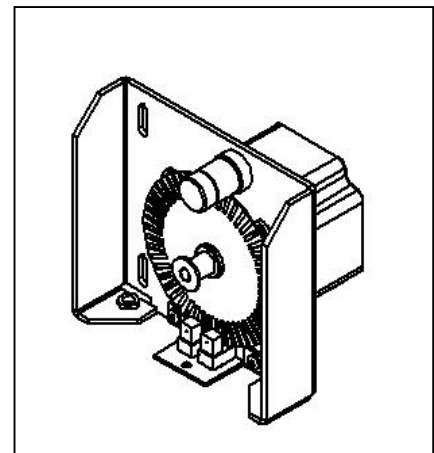

Figure 2: New Pan Motor Mount

¹ Example serial # would be 5000-1460 or 5001-1999.