

read more...

Continued from May 2009 CTI Newsletter

Setting Up Directional Panel Antennas for SHoW DMX

The CTI range of directional panel antennas can significantly improve performance in a SHoW DMX wireless DMX/RDM system, providing they are set up correctly. This document will provide you with a number of techniques for effectively setting up and using panel antennas.

In general, it is best to setup your system well in advance of the show, and to plan to do some testing and adjustment in order to optimize system performance. Whenever possible plan your setup/testing time for the same time of day when your show is scheduled.

Panel antennas are basically flat box shaped units, and radiate primarily from their front "panel" surface. These antennas produce a relatively wide beam of radio waves that can be aimed toward targets and away from things that might cause problems. The CTI # 5632 8dBi Panel Antenna (pictured) has a 40° beam angle, meaning that most of the antenna's energy is shaped into a 40° wide beam (see the beam pattern near right), and much like a light fixture with a 40° beam angle, this antenna can be focused at a desired target or group of targets.



Cables: CTI panel antennas are provided with a short (12") tail with a standard RF "N" female connector, so an adapter such as the CTI # 5638 N to RSMA adapter is required to connect the antenna to a CTI SHoW DMX Transmitter or Receiver. Extension cables may also be used to locate the antenna some distance from the Transmitter or Receiver. All cables, whether short adapters or longer extension cables, must be properly constructed from materials intended for RF applications. Cables that are made from improper components or are poorly assembled can impair or completely block radio transmissions.

All cables will attenuate the signals to the antenna to some degree. For short runs the attenuation/loss will be insignificant with any good RF rated cable, but if longer cables are needed, a special low-loss cable should be used. Low loss RF cable materials are typically thicker and less flexible than the standard cables.

RF cables must be carefully installed. Overly tight bends will increase attenuation, as will excessive numbers of bends. Excessive compression of the cable will also add attenuation, so cable ties should be used carefully.

Attenuation and bend specifications for CTI RF cables are given in the table below:

Cable Type	Attenuation, dB per 100'	Minimum Radius, Single Bend	Minimum Radius, Multiple Bends	Number of Bends Minimum
CTI 5638 N to RSMA Adapter	19	.5"	2"	n/r
LMR 195-DB	19	.5"	2"	n/r
LMR-400-UF	6.8	1"	4"	n/r
Andrew FSJ-50	6.78	1"	1"	30

Installing and Optimizing a Panel Antenna System

Panel antennas may be used together for both transmitters and receivers to create a highly directional system with extended range, good immunity to interference, and reduced interference creation.

- Whenever possible, mount the antennas with direct line of sight.
- For best results, the antennas should be elevated above the ground. In outdoor installations, adding distance from the ground will usually be beneficial. In indoor installations, height is good, but so is distance from ceiling and walls.
- Mount the antennas so they are parallel and are facing each other as shown in the figure below, with the front surfaces facing each other.

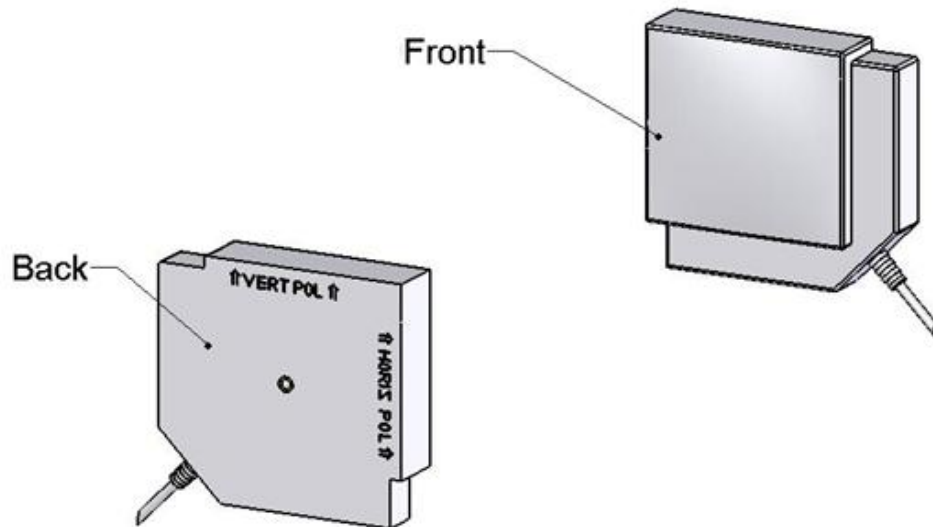

- **Polarize antennas the same way.** Mount the antennas with matched polarity markings pointing up. The antennas in the figure below are polarized vertically (note the “VERT POL” marking on both units is pointing up).

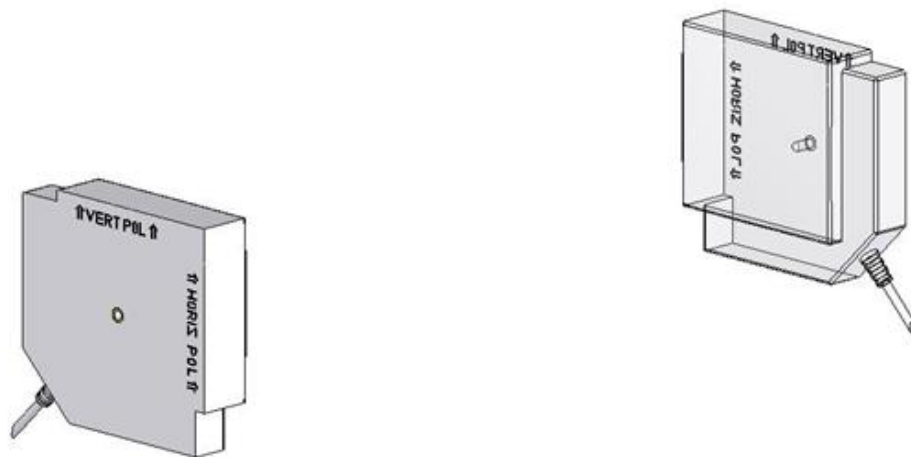

Test the reception of the system. Once you have your system set up, start your DMX source (console, DMX tester, etc.), initiate wireless DMX broadcasting, and check the received signal strength at the receiver. The SHoW DMX Receiver displays received signal strength periodically in the Main menu or continuously in the Misc Settings menu, so you can monitor received signal strength while you fine tune the position of the antennas. Received signal strength is displayed as -dBm and -40 dBm is the best possible value, with higher numbers being weaker than smaller numbers; -40dBm is stronger than -50dBm.

- **Adjust the height and rotation** of the antennas to optimize reception.
- **Check for obstacles between the antennas.** One of the most insidious obstacles to RF is the human body. Be sure and consider your audience location when setting up your system, and locate the antennas so that audience members won't come between the antennas. *As you are setting up and adjusting your system, note what happens to received signal strength when you grasp an antenna to adjust it.* Another common obstacle is glass; some window glass will block radio waves. If you want to broadcast out a window, use a cable to put the antenna outside of the window. CTI panel antennas are rated for outdoor use.
- **Test both vertical and horizontal polarity.** Sometimes, one will work better than the other because of environmental conditions or due to the presence of other wireless systems in the area. If there are other 2.4GHz wireless systems operating within range that are interfering with your SHoW DMX system (or being interfered with by

your system) you may be able to significantly reduce that interference by changing the polarity of your system. Radio systems are frequently setup by default with vertical polarity, so changing your system to horizontal polarity may significantly improve things for all of the systems within range.

The antennas in the figure below are horizontally polarized:

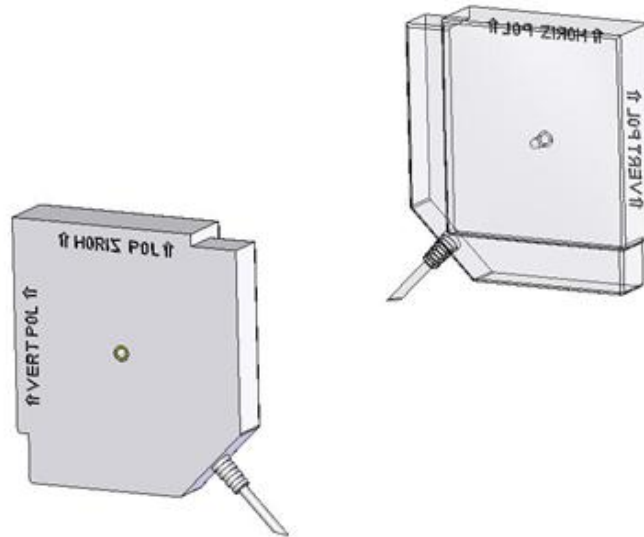

- **Test different power levels.** CTI panel antennas add gain (power) to the broadcast signal and also focus the radio energy directionally. Both effects tend to deliver more of the radio signal to the desired target, so you may not need to operate your transmitter at the highest setting. In some installations, system fidelity *may improve* at lower broadcast power settings. In settings where more than one system is in use, lower broadcast power settings will reduce inter-system interference.

Using Panel Antennas in Combination with Omni-Directional Antennas

Sometimes an installation will not lend itself to panel-to-panel antenna configuration, such as a system in which there is a single transmitter broadcasting to receivers located far apart from each other, so that the receivers could not all be within the beam angle of the transmitter's panel antenna. In setups like this, the system may still benefit from using panel antennas on the receivers and an omni-directional antenna on the transmitter. Using panels on the receivers will increase their range and limit their susceptibility to radio interference from other sources located outside of the beam of their panel antennas.

Many of the same setup techniques will work with omni-to-panel antenna systems that work with panel-to-panel systems:

- **Mount the antennas with direct line of sight.**
- **Adjust height and Rotation** to optimize performance
- **Avoid RF Obstacles**
- **Elevate the antennas** above the ground, but leave clearance for other reflective surfaces indoors.
- **Match antenna polarity.** The figure below shows a vertically polarized panel and omni:

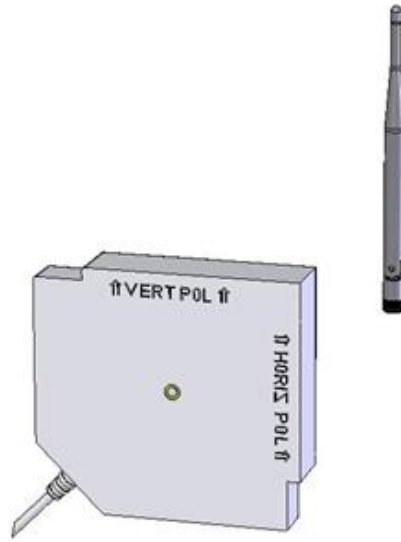

- **Test both vertical and horizontal polarity.** As with panel-to-panel systems, horizontal polarization may improve performance in some systems, The figure below shows a horizontally polarized panel and omni:

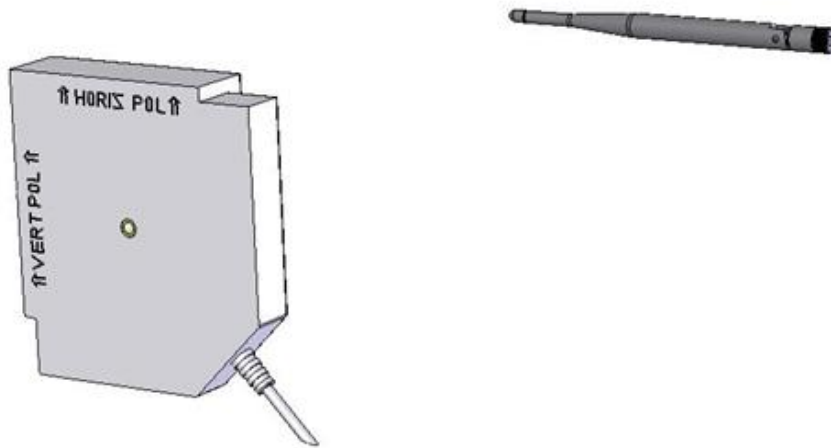

- **Test different power levels.** Lower power levels may actually improve reception due to a reduction in multipath interference.