

CITY THEATRICAL

NEW YORK • LONDON

An Environmental Lights Company

QolorFLEX[®] 2x2.5A 900MHz Multiverse[®] Dimmer P/N 5917

User's Manual

Rev 1.3

© 2024 City Theatrical, LLC



Multiverse[®] Transceivers are covered by U.S. Patent # 7,432,803 and other U.S and foreign patents pending.

Made in USA

US HEADQUARTERS
475 BARELL AVENUE
CARLSTADT, NEW JERSEY 07072
TEL 800 230 9497 / 201 549 1160
FAX 201 549 1161

www.citytheatrical.com

LONDON OFFICE
UNIT 1-3 WYVERN ESTATE, BEVERLEY WAY
NEW MALDEN, SURREY KT3 4PH
TEL +44 (0) 20 8949 5051
FAX +44 (0) 20 7183 6061

Table of Contents

1	Foreword	3
2	Compliance	4
3	Introduction	5
4	Specifications.....	8
5	Configuration	9
6	Troubleshooting	19

List of Tables

Table 1: Part Numbers.....	5
Table 2: Physical Characteristics.....	8
Table 3: Troubleshooting Guide	19
Table 4: Accessories	20

List of Figures

Figure 1: Top and Bottom Detail	6
Figure 2: Opening the Dimmer	7
Figure 3: Inserting Wires.....	7
Figure 4: Multiverse SHoW ID	16

1 Foreword

1.1 Safety Notice

- This product is designed for use in dry locations only. Exposure to rain or moisture may cause damage to the transceiver and increase risk of electrical shock.
- Check all external wiring before applying power.

2 Compliance

This device complies with Part 15 of the Federal Communications Commission (FCC) Rules. Operation is subject to the following two conditions:

- (1) This device may not cause harmful interference.
- (2) This device must accept any interference received, including interference that may cause undesired operation.

CAUTION: Changes or modifications to this unit not expressly approved by the party responsible for compliance could void the user's authority to operate this equipment.

2.1 IC Statement

This device complies with Industry Canada's license-exempt RSSs. Operation is subject to the following two conditions:

- (1) This device may not cause interference; and
- (2) This device must accept any interference, including interference that may cause undesired operation of the device.

Le present appareil est conforme aux CNR d'Industrie Canada applicables aux appareils radio exempts de licence. L'exploitation est autorisée aux deux conditions suivantes :

- (1) l'appareil ne doit pas produire de brouillage, et
- (2) l'utilisateur de l'appareil doit accepter tout brouillage radioélectrique subi, même si le brouillage est susceptible d'en compromettre le fonctionnement.

3 Introduction

QolorFLEX 2x2.5A 900MHz Multiverse Dimmer (P/N 5917) is a small, constant voltage, two-output dimmer designed to be mounted in small spaces such as props, costumes, wands, and candles. It can be controlled wirelessly using City Theatrical’s Multiverse or SHoW DMX Neo wireless DMX/RDM technology, or with wired DMX. This dimmer provides 20-bit PWM resolution and four DMX personality options (two variations of 8-bit and 16-bit control) for extremely smooth dimming at the low end of the dimming curve. Configuration is performed using RDM, such as with a City Theatrical DMXcat®, or with City Theatrical’s USB Configuration program for PC/MAC. A plastic case is included with the QolorFLEX 2x2.5A 900MHz Multiverse Dimmer to allow easy mounting to scenery while enabling removal of the dimmer from the case for wiring and configuration. This dimmer is designed and built in the USA by City Theatrical.

3.1 Features

- Ideal for props and costumes with a low profile
- Wireless or wired DMX input
- Wired DMX output
- Plastic case included
- Compatible with all 900MHz Multiverse and SHoW DMX Neo SHoW IDs (2.4GHz version available as P/N 5916)
- DMX termination selector switch
- Per channel level indicator lights
- Per channel PWM frequency, response time, and curve selections
- Per channel bump buttons, with disable function
- Per channel offsets to balance the point at which each dimmer first turns on (important for perfect low-end balance)
- DMX data loss options
- Micro USB port for firmware updates and configuration
- Low profile latch connections for power, dimmer outputs, and DMX
- Class 2 outputs
- Error detection and signal light for short circuits, over current, over/under voltage, over temperature

3.2 Part Numbers

Table 1: Part Numbers

Part #	Description
5917	QolorFLEX 2x2.5A 900MHz Multiverse Dimmer

5917 QolorFLEX 2x2.5A 900MHz Multiverse Dimmer

3.3 Product Detail

Product is shown larger than actual size.

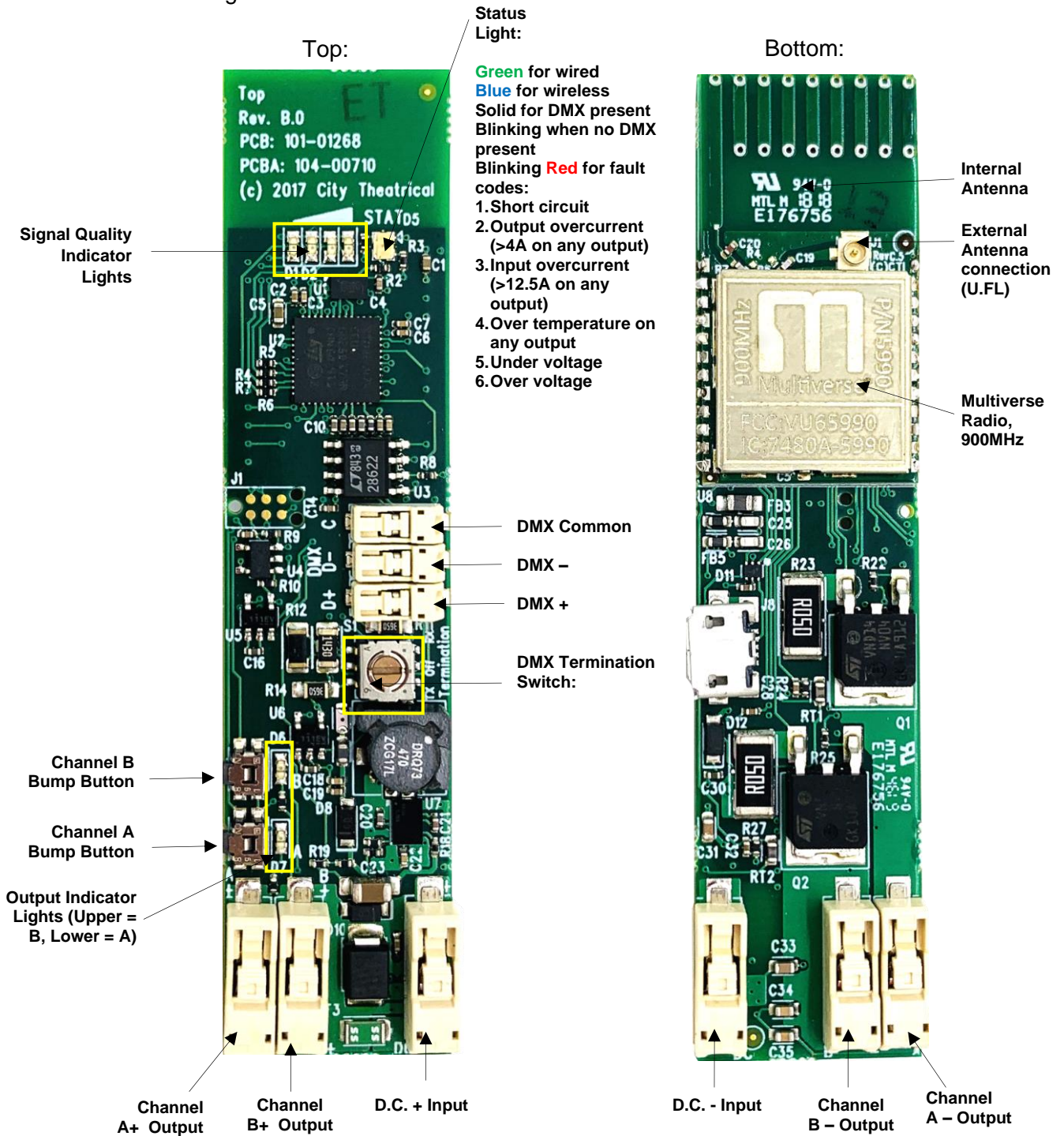

Figure 1: Top and Bottom Detail

Dimensions of bare circuit board*:
3.2" (81mm) L x 0.75" (19mm) W x 0.38" (10mm) H

Dimensions of plastic case:
4.125" (108mm) L x 0.875" (22mm) W x 0.562" (14mm) H

*Shown here larger than actual size.

5917 QolorFLEX 2x2.5A 900MHz Multiverse Dimmer

3.4 Mounting

A plastic case is included with each QolorFLEX 2x2.5A Multiverse Dimmer. Two mounting holes are provided for mounting to scenery. The dimmer may be removed from the case for wiring by prying the locking tab slightly and lifting the cover.

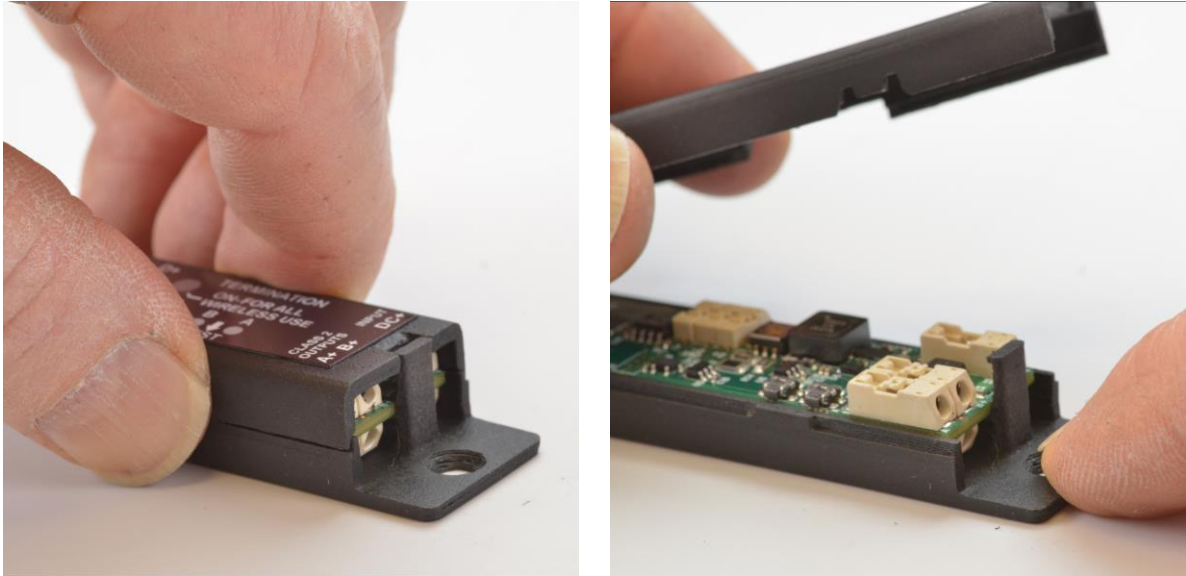

Figure 2: Opening the Dimmer

Insert wires by sliding in (no need to depress tab). Remove by depressing tab.

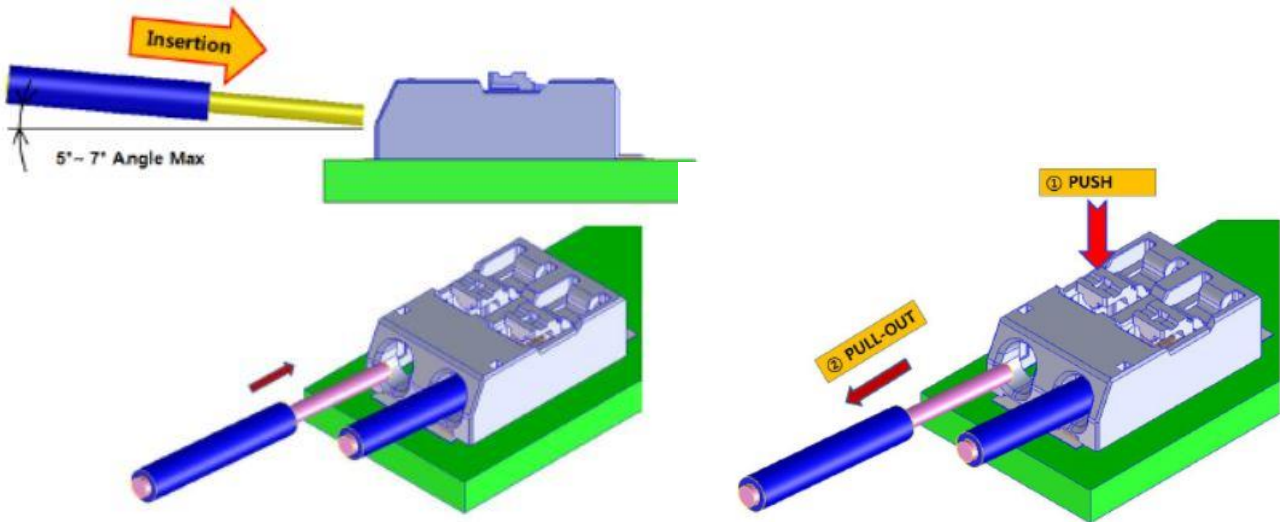

Figure 3: Inserting Wires

4 Specifications

Table 2: Physical Characteristics

Specifications	Description
Frequency	900MHz
Universe(s)	1
Size with Plastic Case	4.125" (108mm) L x 0.875" (22mm) W x 0.562" (14mm) H
Size of Bare Circuit Board	3.2" (81mm) L x 0.75" (19mm) W x 0.38" (10mm) H
Weight	0.05 lbs. (0.02 Kg)
Operating Temperature	0°C to 40°C
Connections	Low profile latch connectors
Construction	NEMA 4 IP20 ABS Plastic
Mounting	Screw holes in tabs on ends of plastic case

Dimming Information	
Voltage Range	5 - 30 VDC
PWM Frequencies (Hz)	60 incan, 1.2K LED, 1.2K candle, 2.4K LED, 5K LED, 12K LED, 24K LED, 50K LED
Power	4A/channel maximum; 5A total
Control Resolution	4 personality options: <ol style="list-style-type: none"> 1. 8-bit (5ch) 2. 16-bit (10ch) 3. 8-bit Tunable White Single (2ch) 4. 16-bit Tunable White Single (4ch)
PWM Resolution	20-bit

Radio Information	
Broadcast Power	Antenna dependent; 100mW EIRP
Broadcast Modes	Adaptive, Full, Low, Mid, High, Max
Ethernet Protocols	N/A
SHoW IDs	Multiverse: 90; Neo: 70
Latency	4ms average
RF Sensitivity	-95dBm
Antenna	Internal, plus U.FL connector for external antenna
RDM Features	RDM Proxy, RDM Responder

Product Information	
Configuration	RDM or City Theatrical USB Configuration Program (PC/Mac)
Use Environment	Indoor
Warranty	One year
Manufacturing Origin	USA
Compliance	RoHS, FCC, IC

5 Configuration

5.1 Installation

The QolorFLEX 2x2.5A 900MHz Multiverse Dimmer requires standard DC power from 5-30VDC. The input voltage must be the same as the load connected to the output ports requires.

Connect your power supply's DC "+" and "-" to the two DC input terminals on the 5917 labelled DC "+" and DC "-".

Connect the "+" lead(s) of the load device(s) to the "+" "OUTPUT" terminals, and connect the "-" leads of the load device(s) to "A" and "B" "OUTPUT" terminals.

Use the "A" and "B" bump buttons to check your connections prior to applying DMX control.

To set DMX Termination Switch. (See label on the plastic case)

- "ON FOR ALL WIRELESS USE"
- "OFF": When used as a wired dimmer and DMX is passing through to another DMX device
- "ON WIRED": When used as a wired dimmer and it is the last device in a DMX chain

For Multiverse and DMX settings, see the RDM section below.

5.2 Multiverse, DMX, and RDM Settings

Important setup information!

Unit ships defaulted to "wired" mode, and RDM configuration begins in that mode.

The status light shows green for wired mode, blue for wireless mode, and red for fault detected (see pages 6 or 19 for fault codes).

Revert to wired mode and reset **all** factory defaults by holding down the "A" and "B" bump buttons together for five seconds until the "STATUS" and "SIGNAL QUALITY" lights flash in unison.

Factory Default Settings

DMX tab

- RDM Traffic Enabled
- DMX Port Label: Label
- Universe 1
- DMX Address 1
- DMX Personality options: 8-bit (5ch), 16-bit (10ch), 8-bit Tunable White Single (2ch), 16-bit Tunable White Single (4ch)

5917 QolorFLEX 2x2.5A 900MHz Multiverse Dimmer

Dimmer tab

- Bump Buttons Enabled
- Apply to All: No
- Device Label: Default Dim 1 Label
- Curve Logarithmic (LED)
- Output Response Time 100ms Ramp Time
- Modulation Frequency 5000Hz-LED
- Control Offset 0

Multiverse Tab

- DMX Input Mode Wired
- SHoW ID 24250
- Antenna Selection Internal
- Output Power Max
- SHoW Key 0

Info

- DMX Fail Mode: Hold last look before changing to a level: Infinite
Hold level before blacking out: Infinite

Setup

To configure as a WIRED device using an RDM controller:

Start by connecting an XLR5M to bare end jumper to the DMX terminals of your 5917. Be careful to maintain polarity. On the XLR connector pin 1 = common, pin 2 = DMX "-", pin 3 = DMX "+". Connect an RDM controller such as a City Theatrical DMXcat.

Using RDM, discover your 5917.

DMX Tab

- Enable or disable RDM traffic downstream of device
- Set DMX Port Label (user selectable name)
- Set Universe (must match between Transmitter and 5917)
- Set DMX Address
- Four DMX Personality options:
 - 8-bit (2ch)
 - 16-bit (4ch)
 - 8-bit Tunable White Single (2ch)
 - 16-bit Tunable White Single (4ch)

Dimmer Tab

- Enable or disable bump buttons
- Select "Apply to All" to apply your choices to both Dimmers. **Note: This must be selected before making any setting changes.**
- Set Device Label (user selectable name)
- Select Dimmer Curve (changes the slope of the dimmer curve, see page 13 for all choices)
- Select Output Response Time (lengthens the dimmer response time to achieve smoother dimming, see pg. 13 for all choices)
- Modulation Frequency (sets the dimming PWM to prevent interference or flickering with

5917 QolorFLEX 2x2.5A 900MHz Multiverse Dimmer

film and video camera shutters, see pg. 13 for all choices)

- Set Control Offset (At very, very low levels in slow fades, the LED emitters may energize at different times. If for instance you are using a bi-color tape, you can offset the time that either of the two emitters begin to fade by raising the value of the Control Offset above zero for that output channel. Try a value of 100 first. Range is -32,768 to +32,767.

Apply DMX and verify system is working.

See page 14 for information on Sensors Tab and page 15 for information on Info Tab.

To configure as a WIRELESS device using an RDM controller:

Start by connecting an XLR5M to bare end jumper to the DMX terminals of your 5917. Be careful to maintain polarity. On the XLR5M pin 1 = common, pin 2 = DMX “-“, pin 3 = DMX “+“. Connect an RDM controller such as a City Theatrical DMXcat.

If starting from default mode, your 5917 will be in Wired mode, and the green status light will be blinking.

Using RDM, discover your 5917.

DMX Tab

- Enable or disable RDM traffic downstream of device
- Set DMX Port Label (user selectable name)
- Set Universe (must match between Transmitter and 5917)
- Set DMX Address
- Four DMX Personality options:
 - 8-bit (2ch)
 - 16-bit (4ch)
 - 8-bit Tunable White Single (2ch)
 - 16-bit Tunable White Single (4ch)

Dimmer Tab

- Enable or disable bump buttons
- Select “Apply to All” to apply your choices to both Dimmers. **Note: This must be selected before making any setting changes.**
- Set Device Label (user selectable name)
- Select Dimmer Curve (changes the slope of the dimmer curve, see page 13 for all choices)
- Select Output Response Time (lengthens the dimmer response time to achieve smoother dimming, see page 13 for all choices)
- Modulation Frequency (sets the dimming PWM to prevent interference or flickering with film and video camera shutters, see page 13 for all choices)
- Set Control Offset (At very, very low levels in slow fades, the LED emitters may energize at different times. If for instance you are using a bi-color tape, you can offset the time that either of the two emitters begin to fade by raising the value of the Control Offset above zero for that output channel. Try a value of 100 first. Range is -32,768 to +32,767.

Multiverse Tab

- (skip setting DMX Input Mode for now)

5917 QolorFLEX 2x2.5A 900MHz Multiverse Dimmer

- Select SHoW ID (Choose any 900MHz SHoW ID to match your Transmitter settings) See page 16 or Multiverse Transmitter, Node, SHoW Baby, or SHoW DMX Neo products manuals for more information on SHoW IDs.
- Select Antenna Setting if not default Internal (other choices are Omni, Panel, Yagi)
- Select Output power if not default Max (other choices are Low, Medium, High)
- Choose a SHoW Key, if desired.

NOTE: Universe, SHoW ID and SHoW Key must match between Transmitter and Dimmer.

- Now change the DMX Input Mode from the default Wired, to Wireless. At this point, you will lose control over the 5917 since it is now a wireless device and will receive an error message, the STATUS light will turn blue and will be blinking if there is no DMX being received, and will be solid blue if you have a Transmitter already properly set and operating nearby.

Apply DMX through a transmitter set on the same SHoW ID, SHoW Key, and Universe, and verify system is working. Note: RDM traffic needs to be enabled at the transmitter to view the wireless 5917 in RDM.

To configure as a WIRED or WIRELESS device using the City Theatrical USB

Configurator controller: Download the City Theatrical USB Configurator from the 5917 webpage on the CTI website, and install the program on your computer (Mac or PC). Connect your computer to your 5917 via a USB to micro USB cable. Select your serial port from the Serial Port tab in the USB Configurator program and select "Connect". Follow the instructions (above) as you would for using an RDM controller for wired or wireless use.

Using the USB Configurator can be easier since you will not lose control when you switch from wired to wireless mode.

5.3 RDM Settings

5917 Menu Descriptions

The full 5917 menu is reachable through RDM via the City Theatrical DMXcat app, other RDM controllers, or the City Theatrical USB Configurator. The following screenshots show what the menus look like in the DMXcat app.

5917 QolorFLEX 2x2.5A 900MHz Multiverse Dimmer

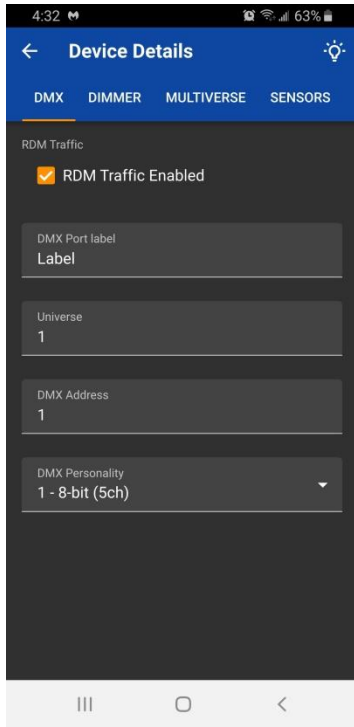

DMX Screen

Use the “Light Bulb” icon to do an RDM identify command to the 5917. All indicator lights will flash.

Enable/disable RDM traffic downstream of the 5917.

Relabel the DMX port on the 5917.

Choose universe number.

Choose starting DMX address for the five dimmers.

Choose from four DMX Personality options:

- 8-bit (5ch)
- 16-bit (10ch)
- 8-bit Tunable White Single (2ch)
- 16-bit Tunable White Single (4ch)

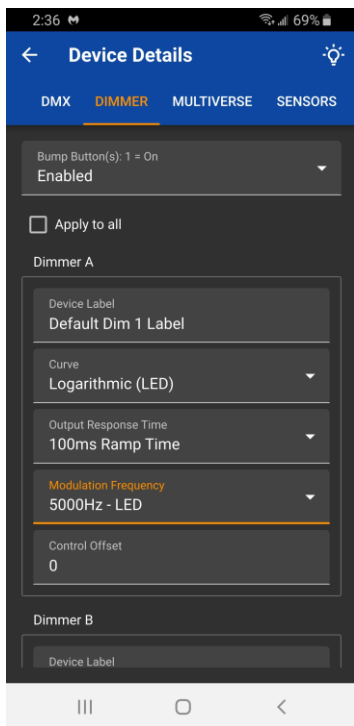

Dimmer Screen

Enable/Disable Bump Buttons.

Apply changes made to all Dimmers.

Edit Label.

Choose Dimming Curve (default is Logarithmic (LED); other choices are Square Law (Incan); Linear; and Non-Dim).

Choose Output Response Time (default is 100ms ramp time; other choices range from 10ms to 400ms).

Choose Modulation Frequency (default is 5000Hz-LED; other choices range from 60Hz Incan to 50000Hz LED, including 1200Hz Candle mode).

Choose Control Offset (default is 0)

5917 QolorFLEX 2x2.5A 900MHz Multiverse Dimmer

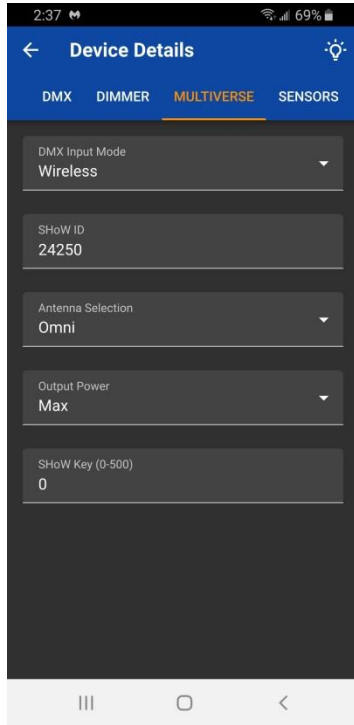

Multiverse Screen

Select Wired or Wireless operation (default is Wired).

Select SHoW ID (default is 24250) See Figure 4 on page 16 about Multiverse SHoW IDs. SHoW ID must match on Transmitter and receiving devices.

Select Antenna in use (default is Internal).

Select Output Power (default is Max).

Select SHoW Key (default is 0) If optional SHoW Key is used, it must match on Transmitter and all receiving devices.

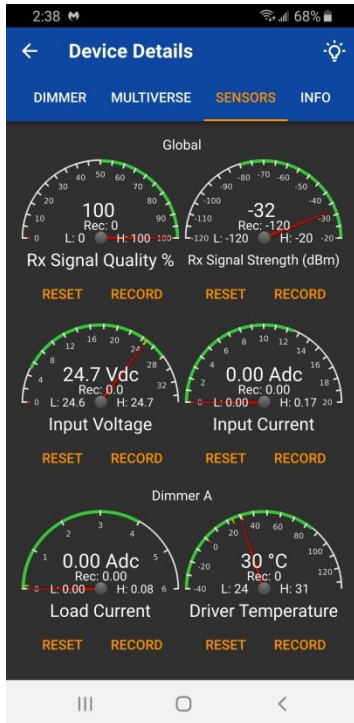

Sensors Screen

Use the Sensors screen to monitor various data collected by the Dimmer.

Press record to record a level for future comparison. Press reset to reset high and low values.

5917 QolorFLEX 2x2.5A 900MHz Multiverse Dimmer

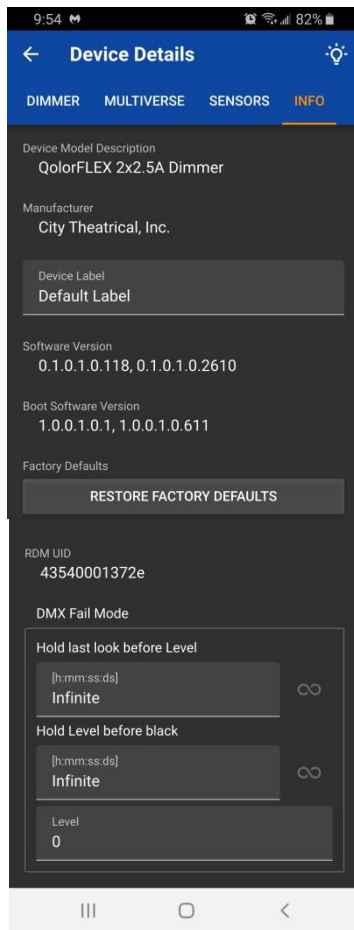

Info Screen

Shows Device Model Description

Shows City Theatrical as manufacturer (made in USA).

Device Label (user editable).

Shows Software Version.

Shows Bootloader Software Version.

Restore all configuration options to their factory default settings.

Shows RDM UID.

DMX Fail Mode: Choose what action device will take upon loss of DMX.

Hold last look for a user selectable amount of time, before changing to a user selectable level (set below).

Hold user selectable level for a user selectable amount of time before blacking out.

Set level.

5917 QolorFLEX 2x2.5A 900MHz Multiverse Dimmer

Multiverse SHoW ID Example: 9302

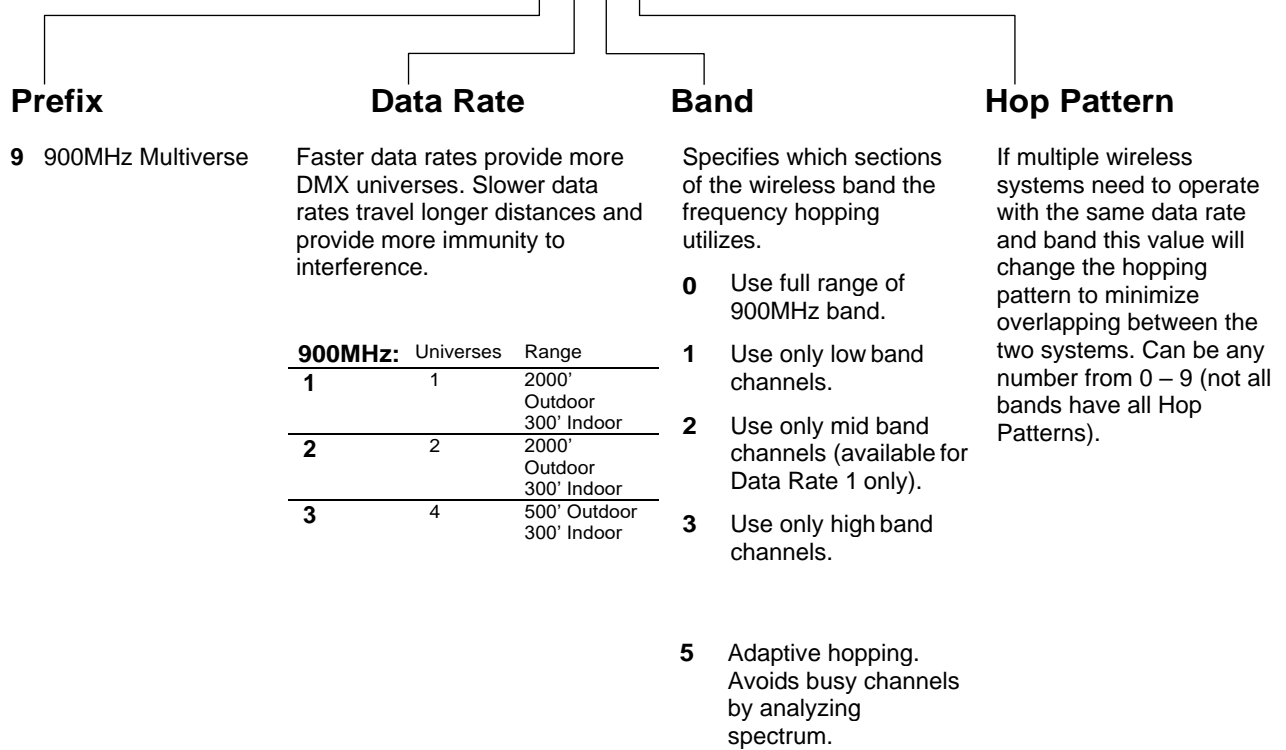

Note: Not all combinations of digits are possible and unused numbers are reserved for future use.

Figure 4: Multiverse SHoW ID

SHoW DMX Neo SHoW IDs

For SHoW DMX Neo SHoW IDs consult the manual for the transmitter you are using, or use these SHoW Baby SHoW IDs:

SHoW ID	Broadcast Area
201	Adaptive hopping
102	Full bandwidth hopping
117	Low band hopping
133	Mid band hopping
149	High band hopping
165	Max band hopping

XLR Pinout	
Pin	Connection
1	Shield (common)
2	Data -
3	Data +
Maintain polarity carefully	

5917 QolorFLEX 2x2.5A 900MHz Multiverse Dimmer

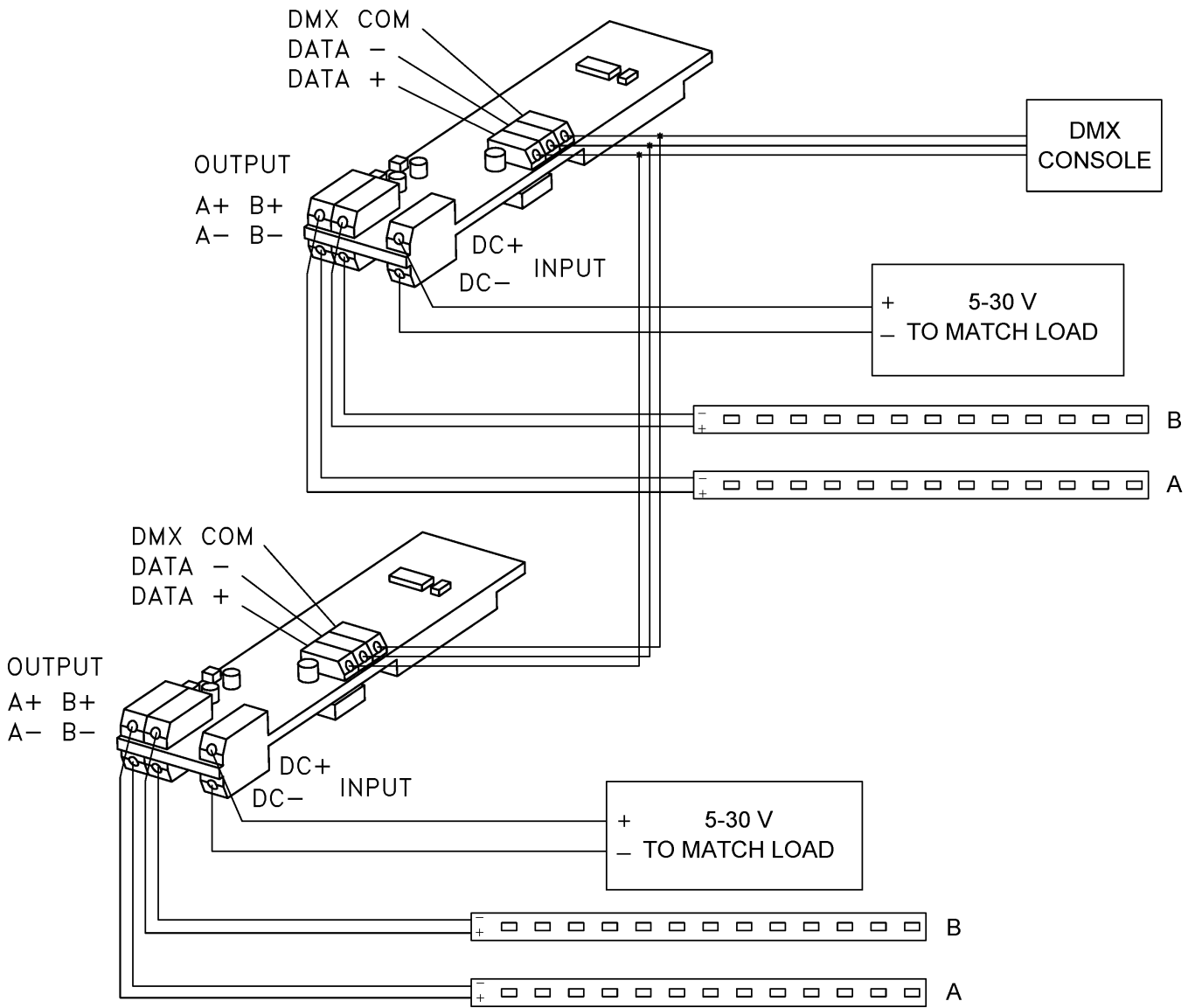

WIRED MODE

5917 QolorFLEX 2x2.5A 900MHz Multiverse Dimmer

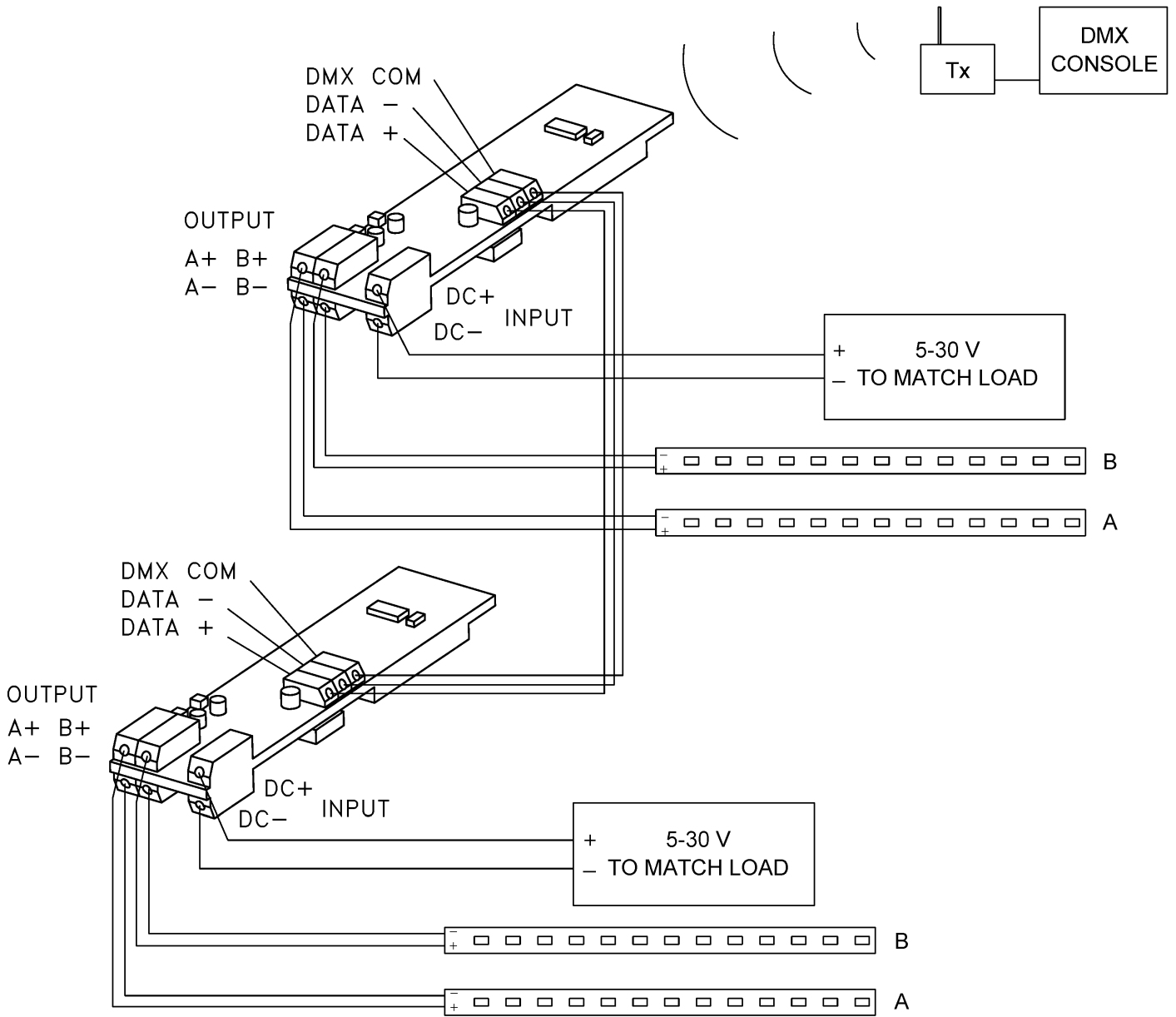

WIRELESS MODE

6 Troubleshooting

Table 3: Troubleshooting Guide

Symptom	Solution(s)
Unit does not power up.	Check that power supply is outputting voltage.
	Check polarity of DC voltage connection from power supply to dimmer.
Unit powers up but can't be controlled.	Use bump buttons to check that output is wired correctly.
	If operating in wireless mode , check that SHoW ID and SHoW Key (if used) and universe match your Transmitter and that DMX present light on dimmer is solid blue.
	Check that "Wireless" has been selected on Multiverse tab of setup screen.
	If operating in wired mode , check that the DMX present light on dimmer is solid green. Check that "Wired" has been selected on Multiverse tab of setup screen.
	Check the starting DMX address, and that the lighting controller is outputting that address. Check console patch.
Additional troubleshooting:	Check polarity of DMX connection. On the XLR5M pin 1 = common, pin 2 = DMX "-", pin 3 = DMX "+".
	For wireless systems, SHoW ID, SHoW Key (if used) and universe must match on Transmitter and all receiving devices.
	If using a wired DMX connection, check polarity of connections carefully using a meter. Pin 1 = common, Pin 2 =DMX "-", PIN 3 =DMX "+"
Dimmer fault codes: Status light will blink red when problems are encountered.	Check LED tape connections carefully. Some tapes use the red wire to designate the "+" connection, and some use the black wire. Check the circuit board of the LED tape carefully to confirm. When wired correctly, the bump buttons will light each circuit before DMX is applied. Troubleshoot tape connection problems first before troubleshooting DMX problems.
	Number of blinks:
	<ol style="list-style-type: none"> 1 Short circuit 2 Output overcurrent (>4A on any output) 3 Input overcurrent (>12.5A on total device) 4 Over temperature on any output 5 Under voltage 6 Over voltage

5917 QolorFLEX 2x2.5A 900MHz Multiverse Dimmer

6.1 Firmware Updates

City Theatrical issues firmware updates occasionally to add features or to fix bugs. The firmware version is found on the Info section of the 5917. Firmware updates are found on the CTI website on the 5917 Downloads tab. Update instructions and the firmware files themselves are found in that download.

6.2 Accessories

Table 4: Accessories

P/N	Name
5955	Plastic Case for P/N 5916/5917

6.3 Customer Service

City Theatrical, Inc.

475 Barell Avenue
Carlstadt, NJ 07072
USA
Phone: (800) 230-9497 or (201) 549-1160
Fax: (201) 549-1161
support@citytheatrical.com

City Theatrical Ltd.

Office 31, Units 1-3, Wyvern Estate, Beverley Way
New Malden, Surrey KT3 4PH
United Kingdom
Phone: +44 (0) 20 8949 5051
support@citytheatrical.com

For additional resources and documentation, please visit our website: www.citytheatrical.com