

CITY THEATRICAL

NEW YORK • LONDON

1507 Follow Spot Yoke Source Four LED Series 3 (EU)

Rev 1.1

© 2023 City Theatrical, Inc.

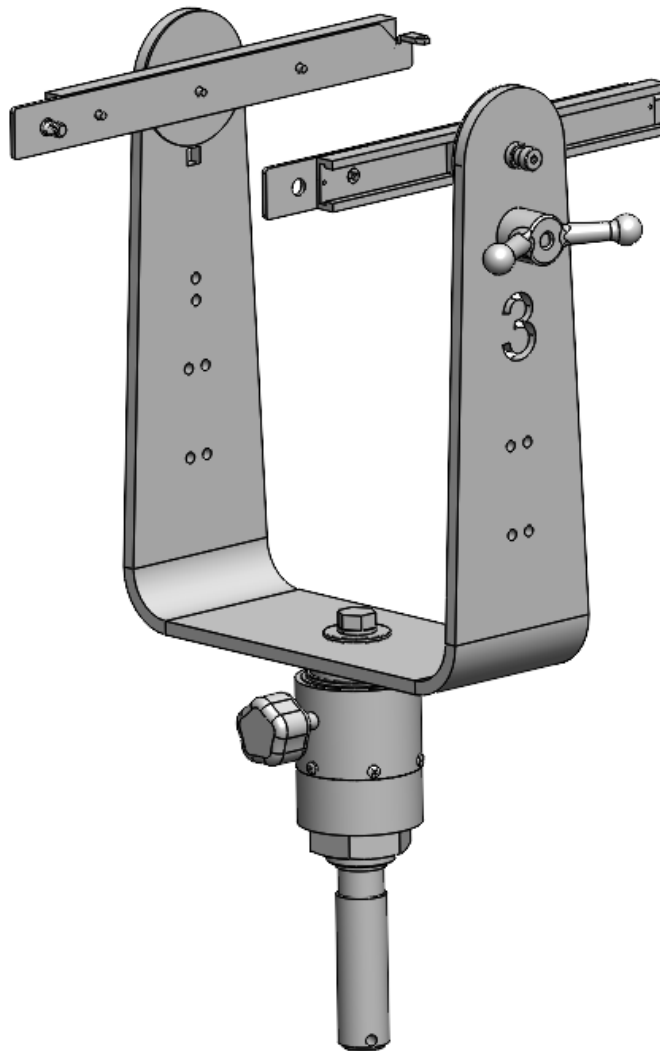

Made in USA

City Theatrical Follow Spot Yoke

Getting Started with the CTI Follow Spot Yoke for Source Four LED Series 3

Congratulations on the purchase of your City Theatrical Follow Spot Yoke for Source Four LED Series 3. The City Theatrical Follow Spot Yoke is a professional quality device that can provide smooth pan and tilt operation to your Source Four LED Series 3. A heavy steel yoke gives mass and prevents vibration, and ball bearings on the pan and tilt create extremely smooth movement, even on very long throws.

The 1507 City Theatrical Follow Spot Yoke can be configured for use with the Source Four™ Series 3 LED fixture. All lenses from XDLT 5° to 50° can be used. A track allows the lighting fixture and any accessories to be perfectly balanced for ease of operation.

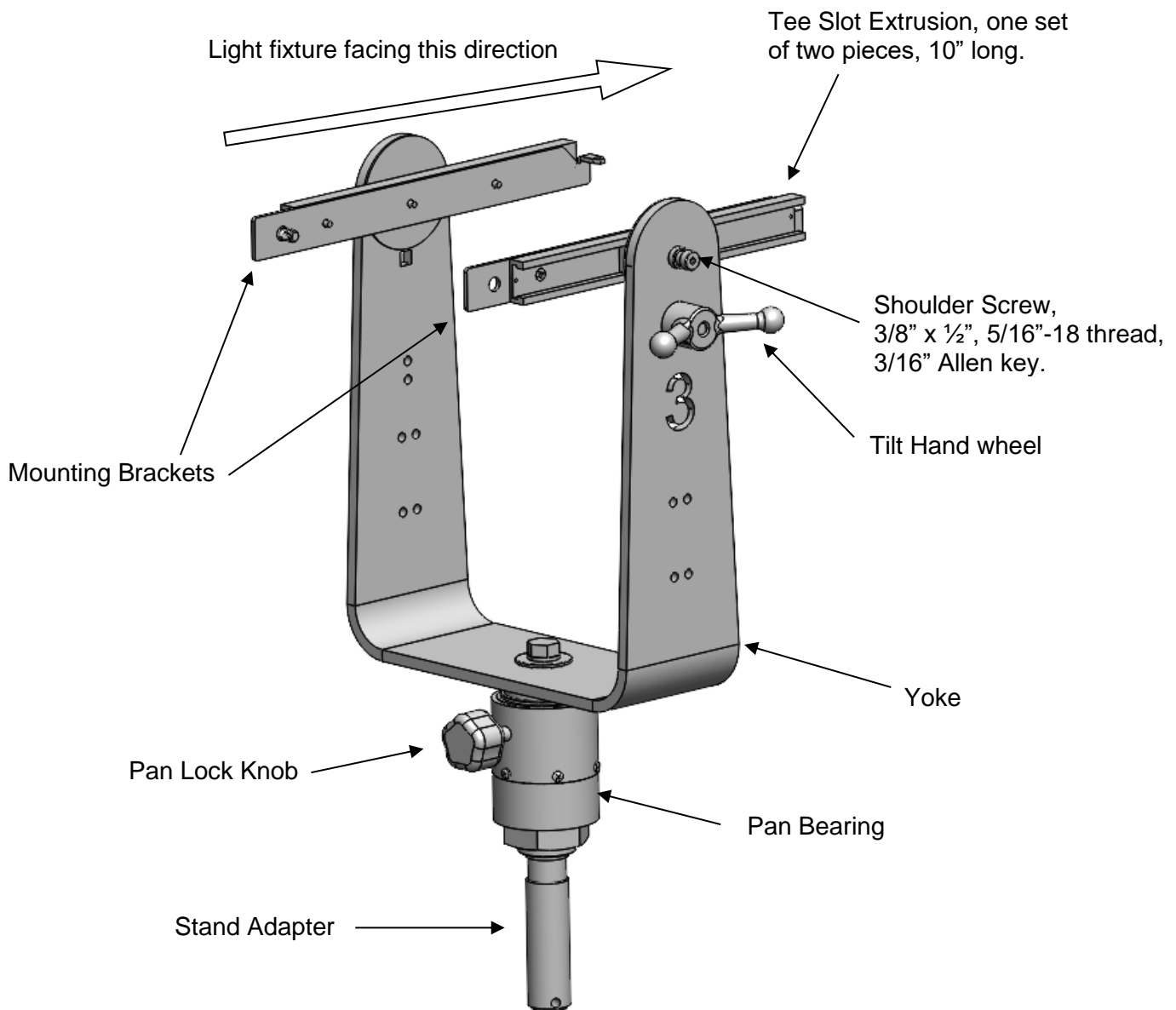

SET FOR RIGHT HAND OPERATION

City Theatrical Follow Spot Yoke

Mounting your Follow Spot Yoke (EU) Source Four LED Series 3

The City Theatrical Follow Spot for Source Four LED Series 3 is recommended to mount on a floor stand. The bottom of the pan bearing has female 1 ½" NPT pipe threads. For this EU version, an adaptor (P/N 1511) is included to fit standard stud receivers.

Mounting Method Example:



City Theatrical Follow Spot Yoke

Preparing Your Lighting Fixture

If you are planning to use a 14°-50° or a 10° Source Four, you will need to remove the shutters from the lighting fixture. This is not necessary, but may be desirable for a 5° Source Four to prevent the shutter blades from accidentally being moved during operation. Remove the shutters by removing the four machine screws which hold the two halves of the Source Four barrel together and exposing the shutter, pressure plate, and shutter spring parts. Remove the shutter blades, but reinstall the pressure plates and springs. Only reinstall the two machine screws on the neck of the barrel. Then go on the next step:

Two Angle Brackets allow your Source Four to be installed in the Follow Spot Yoke Source Four LED. Replace the two ETC Torx machine screws with the enclosed M4x12 pan head Phillips machine screws. Then use the original hex bolt and washer to fasten the angle bracket.

Next, install the two Tee Slot Extrusions using the enclosed #8-32 x 3/8" flat head Phillips machine screws (three screws per extrusion) as shown in the illustration below.

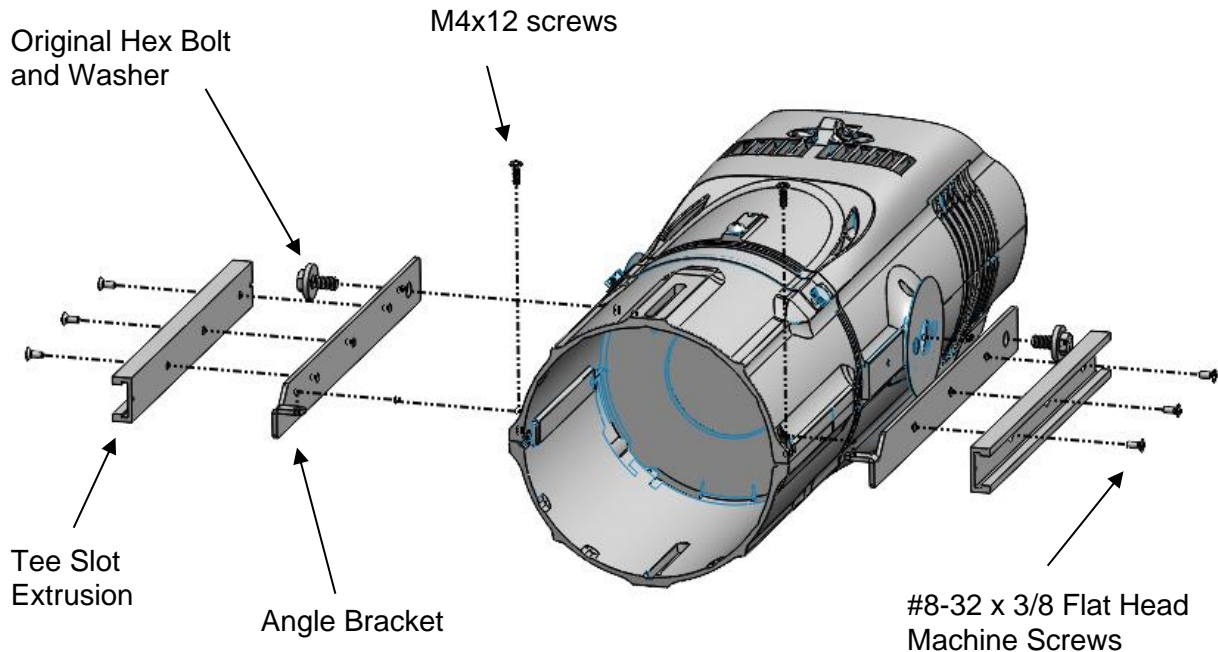

Note: If you experience difficulty installing M4x12 screws, it may be due to incompletely threaded holes on the Source Four barrel. Threads can be formed completely with the following steps:

1. Remove the bottom half of the barrel, locate the threaded holes in the barrel.
2. Using the original Torx thread-forming screw to finish the thread on the bottom half of the barrel.

City Theatrical Follow Spot Yoke

Installing the Source Four into the Follow Spot Yoke

Note the two Tee Blocks that slide into the Tee Slot Extrusion. Using a 3/16" Allen key, slightly loosen the two 3/8" x 1/2" socket head shoulder screws to free the Tee Blocks. Carefully insert the Tee Slot Extrusions onto the Tee Blocks. Tighten the tilt handwheel. Temporarily tighten the shoulder screws.

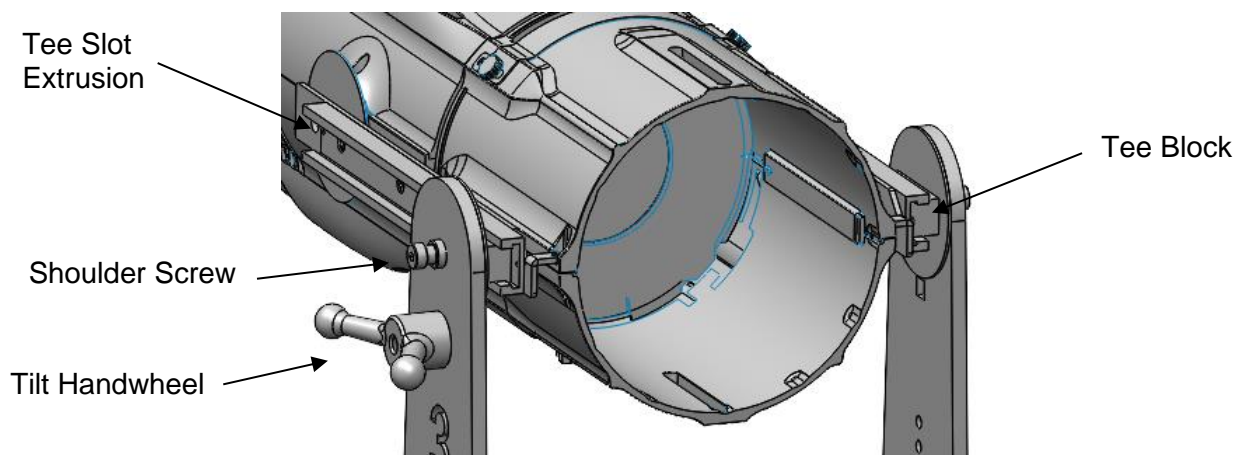

Install four 4-40 x 3/16" pan head machine screws, one in each end of each Tee Slot Extrusion. These screws serve as safety devices to prevent the Tee Blocks from accidentally slipping out of the Tee Slot Extrusion track.

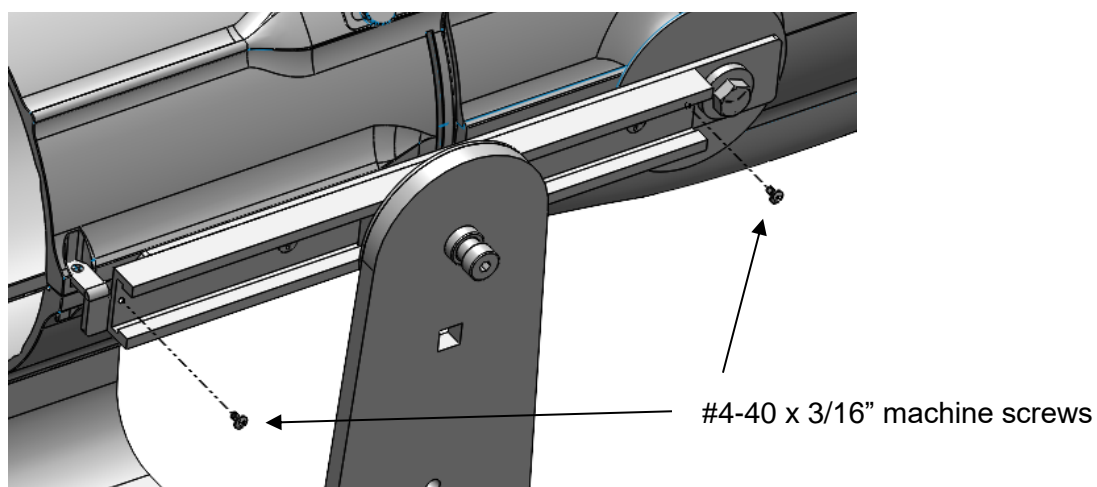

Install the Lens Tube into the Source Four

Install the Lens Tube into the Source Four and install the two #10-32 screws (one plastic thumbscrew and one Philips machine screw) that hold the Lens Tube to the lighting fixture. Plug in the lighting fixture into a switch or dimmer and dress the cable to ensure that it does not restrict the yoke's movement or its balance. Turn on the lighting fixture and adjust the sharpness of the beam to the degree that you think is appropriate.

City Theatrical Follow Spot Yoke

Balance the Lighting Fixture in the Yoke

The lighting fixture can be adjusted forward or backward in the Tee Slot Extrusion to establish a perfect balance point. To test the balance, carefully loosen the tilt locking knob and feel if the fixture is front heavy or back heavy. To adjust the balance, loosen the two shoulder screws and evenly push the fixture forward or backward in the Tee Slot Extrusion until it balances exactly. Lock the shoulder screws again. Test and repeat if necessary.

← Adjust balance as needed →

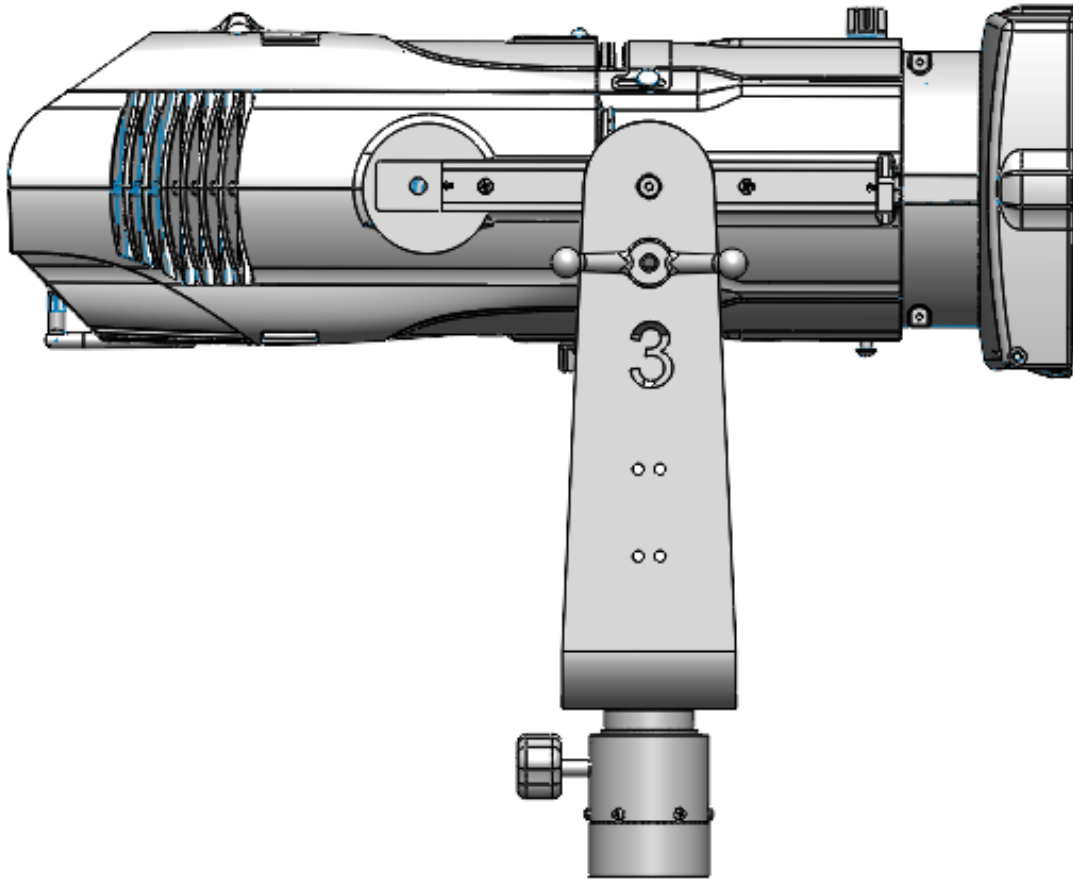

City Theatrical Follow Spot Yoke

Using Other City Theatrical Accessories with Your Follow Spot Yoke

City Theatrical has created a range of accessories to make your Follow Spot more versatile and easier to operate.

Part Number	Name	Use
2180	Drop-In Iris	Change size of beam
1520	Follow Spot Yoke Handle	Provides handgrips at front of Follow Spot.
1519	Follow Spot Source Four LED Series 3 Handle	Clamps onto the rear of Source Four LED Series 3 to provide a handgrip. 1519 manual shows a variety of mounting options.

