

# CITY THEATRICAL I N C

752 EAST 133RD ST. BRONX, NY 10454

718-292-7932 718-292-7482 FAX

<http://www.citytheatrical.com>

## MODIFICATION PROCEDURE FOR *Source Four Fixtures* MANUFACTURED BEFORE JULY 1995

*\*Refer to Figure 1 below for part/s location.*

- 1) Remove the *yoke* from the Source Four fixture.
- 2) Remove the *barrel* from the *reflector housing*.

*\*Looking at the reflector housing -- the housing has three (3) holes in the casting --- one 1/4"-20 hole where the barrel rotation knob is screwed in and two 5/16" holes that secures the fixture to the yoke.*

- 3) On the side **opposite** the 1/4"-20 hole, make a 7/16" mark from the edge centered on the small ridge of that side.
- 4) Using a .201 drill bit, carefully bore a hole in the marked location.
- 5) Thread the hole with a 1/4"-20 tap.

*\*After the new hole has been drilled and tapped, the remaining work to be done is the same as with the new generation Source Four fixtures with the exception of using a 1" long flanged-head mounting screws instead of 1/2" flanged-head mounting screws. Proceed to Step # 3/c of Section 3-2 of the Autoyoke User Manual.*

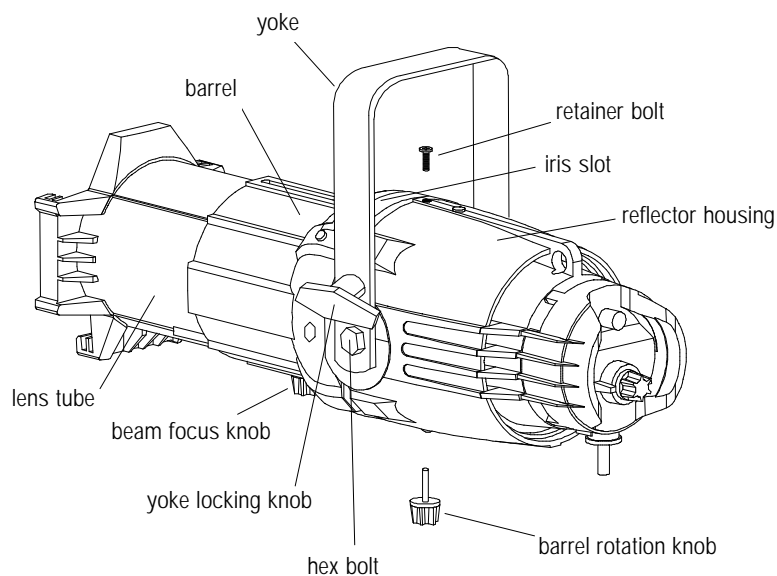

Figure 1