

Revolutionary Wireless DMX/RDM

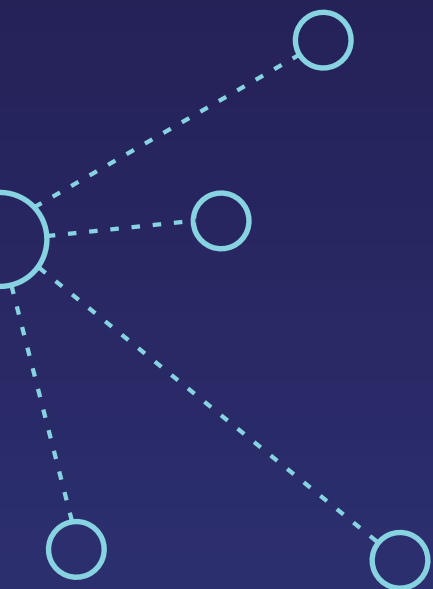
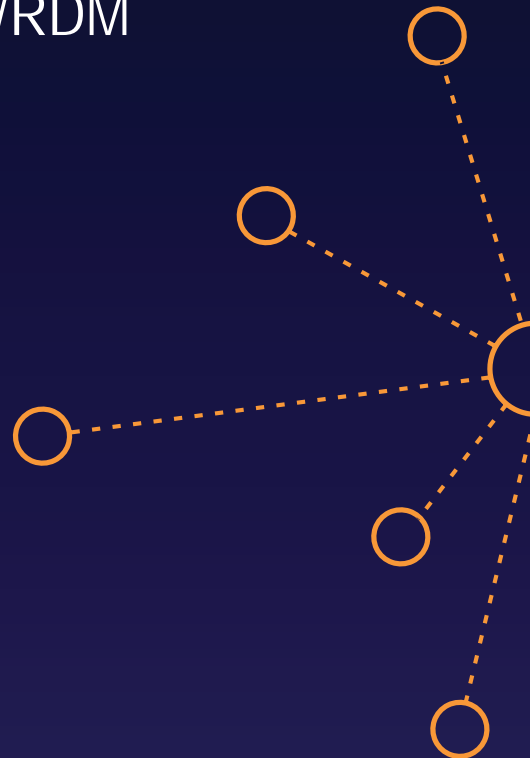

CITY
THEATRICAL
NEW YORK • LONDON

Made in USA

Multiverse: Expanding the World of Wireless DMX

After 20 years of pioneering wireless DMX and RDM for entertainment and architectural lighting, City Theatrical is presenting its new Multiverse® wireless DMX system broadcasting as many as 10 universes of DMX data from a single transmitter, with the ability to use less radio energy than present-day single universe systems.

Multiverse marks our fifth generation of engineering development.

All previous wireless DMX control systems have suffered from a basic limitation: they are only able to transmit and receive a few universes of DMX data before their radio energy overpowers the spectrum and prevents their signals, and the signals of other devices in the venue, from accomplishing their mission. With this constraint, large scale multiple universe wireless systems simply have not been possible to achieve. In addition, the broadcast spectrum in which DMX systems operate has become overcrowded with other radio signals causing additional interference issues.

Faced with these challenges, we began to plan a new system of wireless lighting control that could be scaled up to unprecedented levels without overpowering the spectrum.

Our mission therefore was to be able to deliver more data using less radio energy.

Solution: Multiverse Module

We achieved our goal with the creation of our Multiverse Module. Every product in the Multiverse wireless DMX system is built around these tiny circuit board mounted devices, as an embodiment of this breakthrough technology.



**More Data
Using Less
Radio Energy**

Key Features and Benefits

Flexibility & Scalability

Multiverse components can be set up as single or multiple universe configurations. Using our plug and play Multiverse SHoW Baby® or Multiverse Nodes, single universe systems can be created quickly and easily. Using a single Multiverse Transmitter, you can create a system of up to 10 universes.

Ease of Use

Components are easily set up and users can configure their system and then control its fixtures using Streaming ACN or Art-Net, or convenient smartphone based interfaces such as our DMXcat® app or other Wi-Fi controllers, like Luminair.

2.4GHz & 900MHz Operation

2.4GHz operation is usable worldwide, and for the first time, Multiverse users in North America can use a combination of 2.4GHz and 900MHz frequencies. (Note: 900MHz is not licensed for use outside of North America.)

PoE (Power over Ethernet)

Power the Multiverse Transmitter and receive sACN at the same time, without a power cord or external DC adaptor.

Backwards Compatibility

Multiverse SHoW Baby and Multiverse Node can be used seamlessly with our popular legacy wireless DMX products, including SHoW DMX SHoW Baby®, SHoW DMX Neo®, and SHoW DMX Vero® and SHoW DMX Vero Net®.

RadioScan® Spectrum Analyzer

RadioScan can help improve all Multiverse broadcasts by helping the user select the optimum area in the spectrum to place their broadcast. RadioScan coordinates with Multiverse to help select SHoW IDs.



Why couldn't all DMX data be sent wirelessly before Multiverse?

Until now, wireless DMX lighting control systems have suffered from a basic limitation: They are only able to transmit and receive a few universes of DMX data before their radio energy overpowers the spectrum and prevents their signals, and the signals of other devices in the venue, from accomplishing their mission. Thus, large scale multiple universe installations have not been possible.

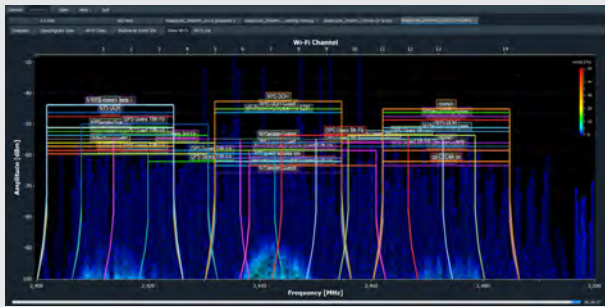

A sample real-life crowded radio spectrum, shown in RadioScan software program.

Faced with this challenge, City Theatrical set out to create a totally new way of controlling live entertainment equipment that would overcome this hurdle and pave the way for the future of wireless data distribution for entertainment and architectural lighting. After years of research, development, and complex engineering, our team of experts has achieved our goal and is proud to offer Multiverse - breakthrough technology that delivers much more DMX data while producing less radio energy.



Smartphone Control

Multiverse Transmitter allows smartphone control of Multiverse equipped lighting fixtures by use of our free DMXcat app.



Forward Error Correction

Allows the Receiver to detect and correct errors that may occur in the wireless transmission of data.



RDM Integration

When Multiverse radios are implemented by a manufacturer of a lighting fixture, they become an integrated part of that device.

Breakthrough Innovations

Multiverse's patent-pending wireless DMX/RDM technology enables scalability of wireless lighting data like never before. It allows larger and larger systems to be scaled up without producing harmful amounts of radio energy that could disrupt other wireless systems in the venue, as well as the following innovative features.



More DMX Data, Less Radio Energy

Multiverse wireless DMX/RDM systems can broadcast up to ten universes of DMX data while using less radio energy than other single universe wireless DMX transmitters.



Simultaneous Dual Band Operation

Broadcast on the 2.4GHz band and the 900MHz band (licensed for use in North America only) at the same time.



mDMX

mDMX is a form of DMX optimized for wireless broadcast that dramatically reduces data being broadcast, thereby reducing unneeded radio energy.



mRDM

Multiverse is able to broadcast RDM information without disrupting the DMX broadcast, a feature unique to Multiverse.



RadioScan

The RadioScan Frequency Analyzer works with Multiverse and guides the user to the best area or the spectrum to place their broadcast.

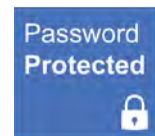

SHoW Key Security

SHoW Key is an additional three-digit code that can be added to the Multiverse SHoW ID to prevent any other system on the same SHoW ID from interfering with your system.



Lock PIN

When using a smartphone with the DMXcat® app, a four-digit PIN can be applied to the Multiverse Transmitter for authorized users.



Low Cost Technology

Multiverse Modules are the lowest cost full featured DMX/RDM product ever, making them ideal for lighting manufacturers.

Multiverse Module*

P/N	Frequency
5990	900MHz
5991	900MHz
5994	2.4GHz
5995	2.4GHz

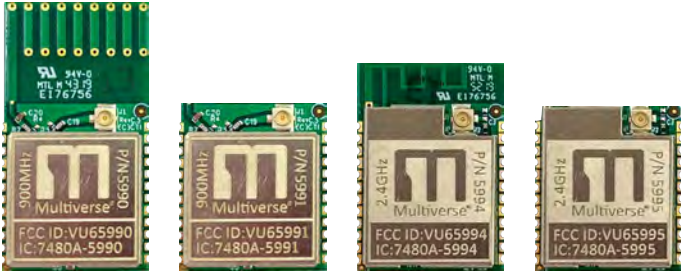

Shown at actual size.

Designed for OEM Partners

Multiverse® Modules are best suited for lighting equipment manufacturers who are interested in adding wireless DMX to their products.

Due to low cost, increased data transport, and ease of design integration, Multiverse Module marks the first time the implementation of a wireless DMX chip in every DMX device is possible. The Multiverse Module is available in two frequency ranges, 900MHz (for use in North America) and 2.4GHz (for use worldwide). Each frequency version can include a PCB trace antenna or not. All versions have a U.FL connector to connect to an external antenna.

Multiverse Modules are available on reels for surface mounting. The OEM Implementation Kit includes a detailed guide, equipment, test gear and more.

Multiverse Receiver Card*

P/N	Frequency
5906	2.4GHz
5907	900MHz

Shown at actual size.

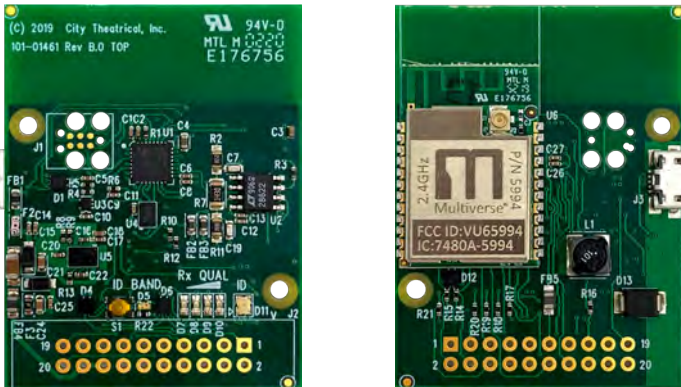

Multiverse Receiver Cards are products that any lighting user, including manufacturers with low volume products, can use to implement wireless DMX/RDM into entertainment projects or equipment, including props, costumes, or lighting fixtures, in a simple way.

Multiverse Receiver Cards are full Multiverse wireless DMX/RDM receivers without the housing, XLR connectors, and user interface as used in wireless DMX receiving products like the Multiverse Node and Multiverse SHoW Baby. Multiverse Receiver Cards include an internal antenna and a connection to an optional external antenna. Configuration for Multiverse Receiver Cards is done via RDM with the DMXcat app, or with City Theatrical's USB Configuration Program for PC/Mac. In addition to receiving wireless DMX and outputting wired DMX, the Multiverse Receiver Card can output 0-10V, and has four PWM control outputs.

Implement Wireless DMX/RDM Into Lighting Equipment In A Simple Way

Key Features

- Supports ANSI E1.11 DMX512-A and E1.20 RDM
- DMX RS-485 driver on board with $\pm 60V$ protection
- Signal Quality LEDs on board and external connections
- SHoW ID RGB LED on board and external connections
- Multiverse Band LED on board and external connections
- Wide input voltage range, 5V to 30Vdc
- Footprint 50mm(2") x 38mm(1.5")
- +3.3Vdc output to power low current hosts
- Configurable over USB micro B connector
- Firmware updatable over USB micro B connector
- Advanced Mode features: 0-10V output; Four PWM control outputs



*Not sure if you need the Multiverse Module or Multiverse Receiver Card?

See our decision making tool at:
<https://bit.ly/3PretD9>

Multiverse SHoW Baby

P/N	Frequency
5900	2.4GHz



Right out of the box, Multiverse® SHoW Baby® is compatible with all SHoW Babys ever made.

With tens of thousands of units sold since their introduction in 2011, SHoW Baby plug and play transceivers set the standard for ease of use and reliability at an affordable price point. The addition of Multiverse radio technology enhances the performance even more.

City Theatrical's Multiverse SHoW Baby is a wireless DMX transceiver that delivers breakthrough plug and play wireless DMX and RDM transmission. In its default mode, it works like all other SHoW Baby Transceivers with six user selectable SHoW IDs. By connecting an RDM controller, like DMXcat® Multi Function Test Tool, all of the revolutionary new 2.4GHz Multiverse SHoW IDs are accessible. Users can add to their existing SHoW Baby systems, build new single universe Multiverse systems, or use Multiverse SHoW Baby as a receiver on multiple universe systems with a Multiverse Transmitter.

The Fourth Generation of the Original Plug & Play Wireless DMX Transceiver System

Key Features

- Built-in 2.4GHz Multiverse radio (for worldwide use)
- All SHoW DMX Neo and 2.4 GHz Multiverse SHoW IDs are available through RDM
- In Multiverse mode, compatible with all Multiverse products. In SHoW DMX Neo mode, compatible with all SHoW DMX Neo legacy products.
- Plug and Play selection of Transmitter or Receiver function
- 5 Pin XLR DMX input and output
- 7.5 to 30VDC power input
- Molded plastic enclosure

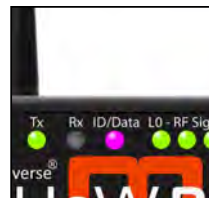

Transmitter set to SHoW ID 117

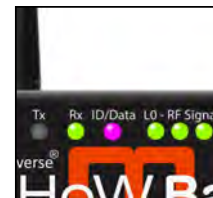

Receiver set to same SHoW ID



Set SHoW IDs on back of unit

What's in the box:



Tx SCHEMATIC

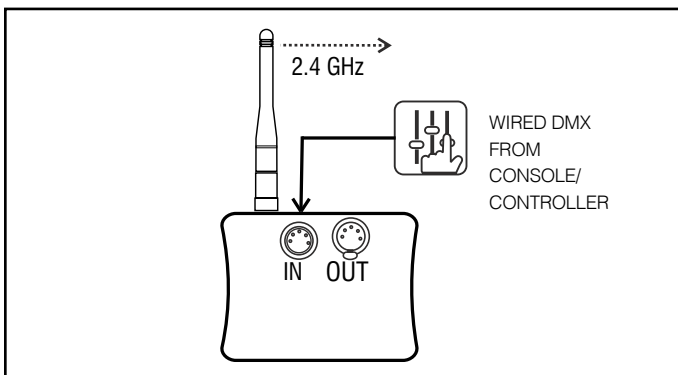

Rx SCHEMATIC

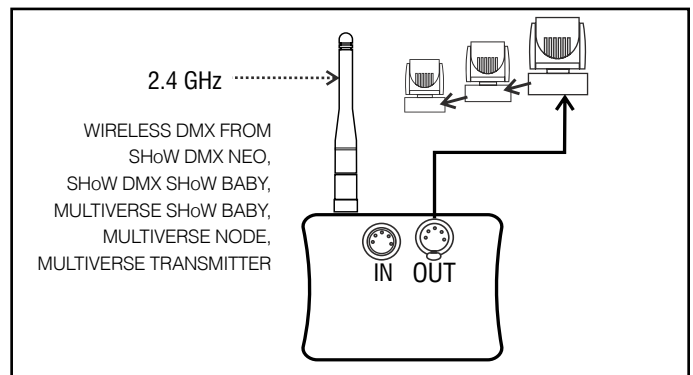

Multiverse Node

P/N	Frequency
5902	900MHz/2.4GHz
5903	2.4GHz



The Multiverse® Node is the first building block of the Multiverse system.

Each Multiverse Node is a transceiver. As a single universe transmitter, it functions in a similar plug and play manner to our Multiverse SHoW Baby®, but contains two radios (North America version only) and a full user interface. As a receiver, it is the primary single universe stand alone receiver in the Multiverse system, and can be part of a larger multi-universe setup.



Tx SCHEMATIC

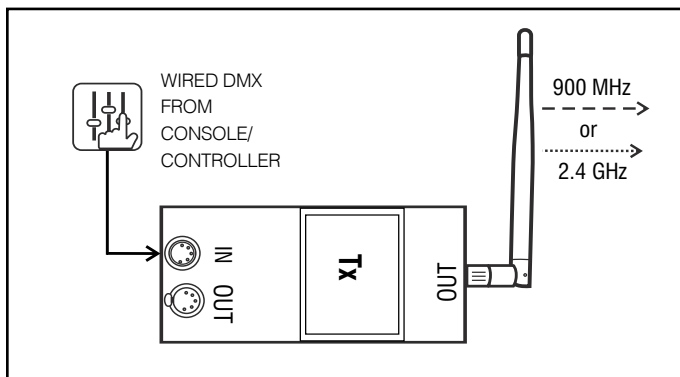

Single Universe Plug and Play Simplicity

Key Features

- Built-in 2.4GHz (for worldwide use) and 900MHz (for use in North America only) radios allow the user to select which single universe to transmit, and which radio band to use via the SHoW ID
- As a single universe receiver as part of a multi-universe system, users can select which universe to receive
- A very simple user interface to set SHoW ID and universe
- Rugged cast aluminum enclosure
- A single dual band antenna
- 5 Pin XLR DMX input and output
- 5 to 30VDC power input via locking barrel connector



Pipe Mount



Simple onboard setup



Back of unit

What's in the box:



Rx SCHEMATIC

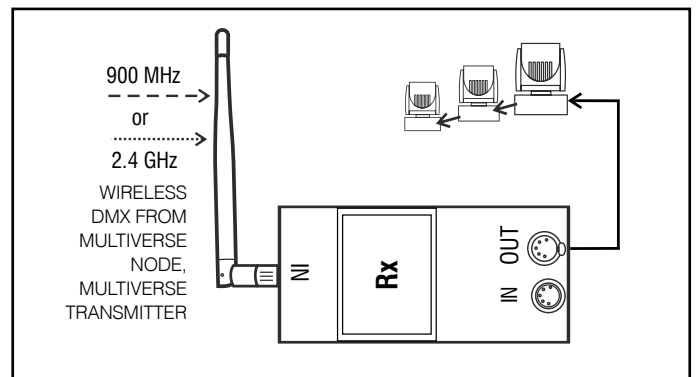

Multiverse Transmitter

P/N	Frequency	Universes
5910	900MHz/2.4GHz	9
5911	2.4GHz (x2)	10
5912	900MHz (x2)	8



The Multiverse® Transmitter opens a new world in wireless DMX/RDM.

Its Ethernet input allows it to take in Streaming ACN (sACN) or Art-Net and to transmit between eight and 10 user-selectable universes of DMX/RDM, depending on the Multiverse Transmitter used, with the ability to use less radio energy than a present day single universe wireless DMX transmitter.

The Multiverse Transmitter has a Bluetooth radio receiver built in that allows it to communicate with City Theatrical's multi award winning DMXcat® app from the user's smartphone. This gives the user smartphone control of any lighting fixture that is part of the Multiverse setup, whether it is a lighting fixture with a Multiverse Module inside, a lighting fixture receiving its data from a Multiverse Node, or any wired fixture downstream of those devices.

The Multiverse Transmitter is Wi-Fi enabled, allowing for communication and control from tablet based Wi-Fi lighting controllers like Luminair.

What's in the box:



Multiple User Control Using Bluetooth Or Wi-Fi

Key Features

- Four radios: Bluetooth and Wi-Fi for inputs, and two for Multiverse wireless DMX/RDM output: 900MHz and 2.4GHz (for P/N 5910), 2.4GHz and 2.4GHz (for P/N 5911), and 900MHz and 900MHz (for P/N 5912)
- Ethernet input for sACN and Art-Net
- All setup and user choices made with our free DMXcat app
- Rugged cast aluminum enclosure
- A hanging bracket is included for hanging from a pipe or truss
- Additional user control via DMXcat app or Luminair



Pipe Mount



Pipe Mount

SCHEMATIC (FOR P/N 5910)

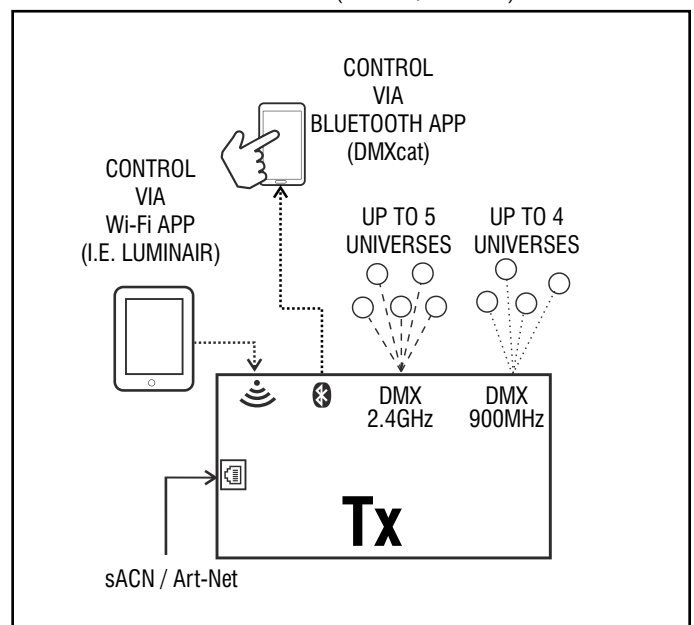

Multiverse Vero Transceiver

P/N	Frequency
7400-5902	900MHz/2.4GHz
7400-5903	2.4GHz



The Multiverse® Vero Transceiver brings the advanced features of the Multiverse wireless DMX/RDM system to outdoor installations for architecture and entertainment.

The 7400-5902 Multiverse Vero Transceiver 900MHz/2.4GHz contains two radios, 2.4GHz (for worldwide use) and 900MHz (for use in the Americas only), which allow the user to select which single universe to receive, and which radio band to use via the Multiverse SHoW ID.

The Multiverse Vero Transceiver is housed in a NEMA 4/ IP66 package that provides protection from the outdoor elements. Its internal backlit LCD display makes setup easy and gives feedback on system performance. Each unit comes with a dual band 2.5dBi outdoor omni-directional Antenna.



Outdoor-Rated Wireless DMX/RDM

Key Features

- Built-in Multiverse 2.4GHz (for worldwide use) and 900MHz (for use in the Americas only) Frequency Hopping Spread Spectrum radio
- Compatible with all Multiverse and legacy SHoW DMX Neo products
- User can select a single universe to receive
- Four button user interface screen to set SHoW ID, universe, and other functions
- DMX In (when used as transmitter) and Out (when used as receiver) via 3 pin Screw Terminal
- Rugged weatherproof aluminum enclosure
- Antenna: Omni Broadband, 900MHz/2.4GHz, 2.5dBi/2.5dBi

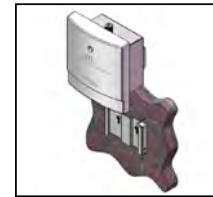

Wall Mount



Pipe Mount



RadioScan Spectrum Analyzer

P/N	Frequency
5988	902-928MHz and 2.4-2.483GHz



RadioScan Spectrum Analyzer is a 900MHz and 2.4GHz spectrum analyzer that enables you to easily visualize radio energy that is otherwise invisible to you.

Using RadioScan helps you to create a broadcast plan that optimizes available spectrum in your area, and helps prevent interference with other mission critical radio devices near you.

RadioScan shows all radio activity near you in your chosen frequency, including frequency hopping gear like wireless DMX, as well as Wi-Fi networks, Bluetooth, wireless headsets, video transmitters, cordless phones, baby monitors, and microwave ovens. RadioScan can view spectrum data either in Spectrogram View or Waterfall View, and snapshots can be taken of both in the program. Scans of any length can be recorded, saved, emailed and played back with the RadioScan software, without the need for the RadioScan hardware dongle.

For users of Multiverse® wireless DMX/RDM products, RadioScan will guide you in creating the optimum broadcast plan for your production.



Easily Visualize Radio Energy and Create Broadcast Plans



RadioScan®

Key Features

- 900MHz and 2.4GHz spectrum analyzer with dual band antenna
- Finds all radio activity nearby in chosen spectrum
- Identifies SSID and signal strength of Wi-Fi networks
- Shows either Spectrogram or Waterfall view
- Can record and play back scans of unlimited length
- Takes and saves snapshots
- Records text notes on scans
- Prompts Multiverse SHoW IDs

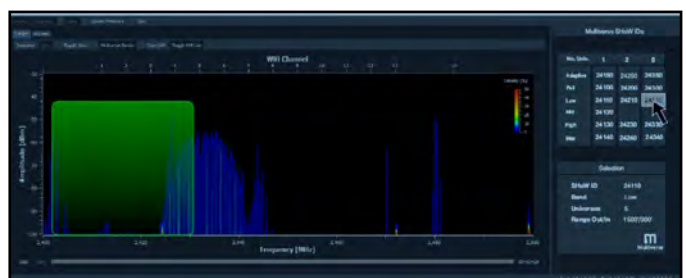
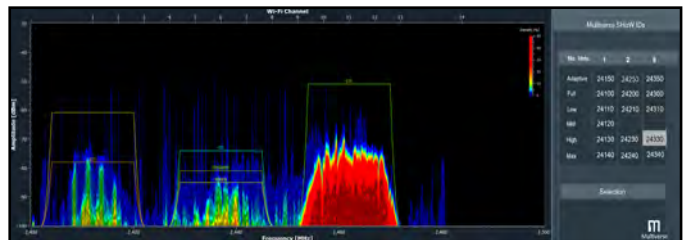

DMXcat Multi Function Test Tool

P/N | 6000

Anyone Can Turn on Any DMX Device, From an LED PAR to a Complex Moving Light

DMXcat®



City Theatrical's DMXcat system is designed for use by the lighting professional who is involved with the planning, installation, operation, or maintenance of theatrical and studio lighting equipment.

The system consists of a small interface device and a suite of mobile applications. Together, they combine to bring DMX/RDM control plus several other functions to the user's smartphone. DMXcat works with Android, iPhone, and Amazon Fire, and can function in seven languages: Spanish, French, German, Italian, Korean, Japanese, and English, depending on your mobile phone's native language setting.

The DMXcat's interface device is a compact battery powered unit which fits easily in a pocket or tool pouch or may be worn on a belt. It uses Bluetooth LE technology for communication with the smartphone/applications (up to 50' range). Without being physically connected, the user can move about the workspace and operate the various apps while still using the phone for on-the-job communication. The device's five pin XLRF connector/cable assembly allows it to be connected to any point in a DMX data chain to allow testing and or control of the various DMX/RDM slot functions. It is charged using a standard USB to Micro USB cable and charger.

Key Features

- Built-in LED flashlight
- Audible alarm (for locating a misplaced unit)
- LED status indicator
- XLR5M to XLR5M Turnaround
- Removable belt clip
- Optional accessories include: XLR5M to RJ45 Adapter, XLR5M to XLR3F Adapter, XLR5M to XLR3M Turnaround, and Belt Pouch

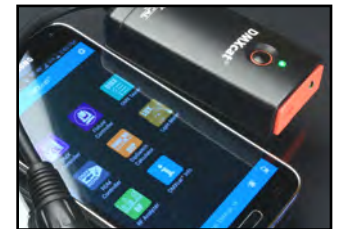

Apps Included with the basic configuration include:

- **DMX Controller:** A single universe (512) DMX channel controller with two user interfaces.
- **Fixture Controller DMX:** Test app for multi-attribute fixtures with built in database of lighting fixtures.
- **RDM Controller:** App for bi-directional communication/control of RDM enabled devices.
- **DMX Tester:** Permits users to analyze and or adjust settings for transmitting or receiving DMX.
- **RF Spectrum Analyzer (Android only):** For surveying and visualizing Wi-Fi networks.
- **DIP switch calculator:** This app simplifies the configuring of DIP switches used for setting DMX addresses.
- **Light Meter (Android only):** Useful for setting light levels for on-camera use.



What's in the box:

Multiverse Studio Receiver

P/N	Frequency	Universes
5904	900MHz/2.4GHz	1
5905	2.4GHz	1



The Multiverse Studio Receiver brings the advanced features of the Multiverse wireless DMX/RDM system to the film, video and events world, where fast setup and reliability are key objectives.

The Multiverse Studio Receiver contains a long-life lithium-ion polymer battery giving 20 hours of use. The Multiverse Studio Receiver has a full four button user interface with a backlit LED display that makes setup easy and gives feedback on system performance.

The 5904 Multiverse Studio Receiver contains two built-in radios, 2.4GHz (for worldwide use) and 900MHz (for use in the Americas only), and the 5905 Multiverse Studio Receiver contains a 2.4GHz radio, which allow the user to select which single universe to receive, and which radio band to use via the Multiverse SHoW ID.

The DMX corded connector allows the Multiverse Studio Receiver and external antenna to hang below the lighting fixture, giving improved data fidelity.

What's in the box:



*The P/N 5969 External Power Supply, 100-240VAC input, 5VDC output USB-A shown comes with the P/N 5904 Multiverse Studio Receiver 900MHz/2.4GHz model only.

20-Hour Battery Life Wireless DMX Receivers Designed for Film, Video, and Events



Key Features

- Choice of Broadcast Radio: Transmit and receive on either the 2.4GHz band or the 900MHz band. (P/N 5905 transmits and receives on the 2.4GHz band only.)
- Long Life Rechargeable Battery: 20 hour battery life with default settings
- Rugged and Splashproof: An IP61 rated plastic case, making it splashproof and rainproof (but not for permanent outdoor use).
- User Selectable SHoW IDs: City Theatrical has always produced wireless DMX products that allow the user to select the optimum transmission method. Users may select full bandwidth hopping, hopping limited to a section of the spectrum (including areas of the spectrum outside of the Wi-Fi range), or adaptive hopping.



Multiverse Studio Kit

P/N	Frequency	Universes
5938	900MHz/2.4GHz	1 - 9
5939	2.4GHz	1 - 10

All the Tools Lighting Technicians Need to Quickly Plan, Setup, and Operate Wireless DMX/RDM for Film, Video, and Events



The Multiverse Studio Kit brings the advanced technology of Multiverse wireless DMX/RDM system to the film and video world, featuring Receivers with 20 hour battery life and contactless charging in an easy to use kit.

The Multiverse Studio Kit provides all the tools lighting technicians need to quickly plan, setup, and operate wireless DMX/RDM on set. It includes:

- Six battery powered Multiverse Studio Receivers
- One Multiverse Transmitter with hanging bracket and clamp (for multi universe broadcasts)
- One Multiverse Node with hanging bracket and clamp (for single universe broadcasts)
- One DMXcat Multi-Function Test Tool (to turn on and troubleshoot any lighting fixture on set)
- One RadioScan Spectrum Analyzer (for broadcast planning)
- Six USB-A to USB-C cable, 1m
- Six Power Supplies, 100-240VAC input, 5VDC output*
- One Power Cord, PowerCON True 1, 8' long
- Pelican case with contactless charging

Just drop the Multiverse Studio Receiver onto its slot in the Multiverse Studio Kit case, and it will begin charging. Individual chargers and USB cables are also included to enable charging or powering individual units outside the case.

*External power supplies only come with the P/N 5938 model.

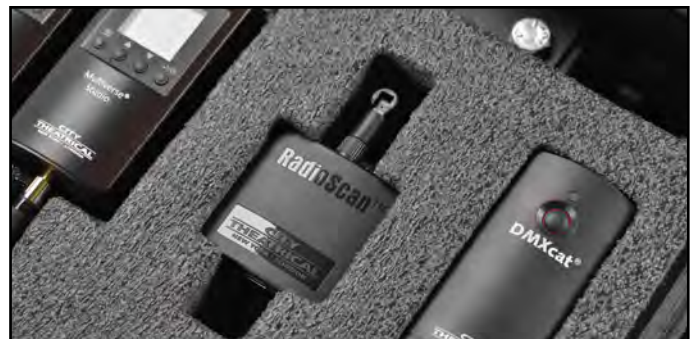

Multiverse Studio Receivers charging in the Multiverse Studio Kit.

Multiverse Studio Add On Kit

P/N	Frequency	Universes
5940	900MHz/2.4GHz	1 - 9
5941	2.4GHz	1 - 10



Add Receivers to a Multiverse Studio Kit System in a Contactless Charging Case



Expand your Multiverse Studio Kit

The Multiverse Studio Add On Kit provides six additional Multiverse Studio Receivers for users to expand upon their full P/N 5938/5939 Multiverse Studio Kits.

Just drop the Multiverse Studio Receiver onto its slot in the Multiverse Studio Add On Kit case, and it will begin charging. Individual chargers and USB cables are also included to enable charging or powering individual units outside the case.

Each Add On Kit includes:

- Six Multiverse Studio Receivers
- Six USB-A to USB-C cable, 1m
- Six Power Supplies, 100-240VAC input, 5VDC output*
- One Power Cord, PowerCON True 1, 8' long
- Pelican case with contactless charging



Multiverse Studio Receivers charging in the Multiverse Studio Add On Kit.

*External power supplies only come with the P/N 5940 model.

QolorFLEX 2x2.5A Multiverse Dimmer

P/N	Frequency	Universes
5916	2.4GHz	1
5917	900MHz	1

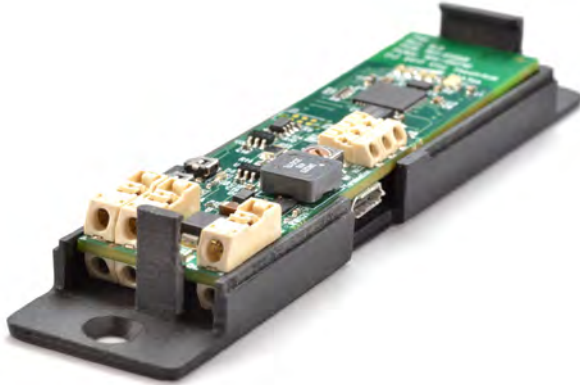

QolorFLEX® 2x2.5A Multiverse® Dimmers are small, constant voltage, two-output dimmers designed to be mounted in small spaces such as props, costumes, wands, and candles.

These dimmers can be controlled wirelessly using City Theatrical's Multiverse or SHoW DMX Neo wireless DMX/ RDM technology, or with wired DMX.

Each dimmer provides 20-bit PWM resolution and extremely smooth dimming at the low end of the dimming curve, with four DMX personality options, including:

- 8-bit (5ch)
- 16-bit (10ch)
- 8-bit Tunable White Single (2ch)
- 16-bit Tunable White Single (4ch)

Configuration is performed using RDM, such as with a City Theatrical DMXcat®, or with City Theatrical's USB Configuration program for PC or Mac.

A plastic case is included with each QolorFLEX 2x2.5A Multiverse Dimmer to allow easy mounting to scenery while enabling removal of the dimmer from the case for wiring and configuration. These dimmers pair well with tunable white QolorFLEX LED Tapes for ideal use in areas where space is a concern. QolorFLEX 2x2.5A Multiverse Dimmers are designed and built in the USA by City Theatrical.

Designed for Props,
Costumes, Wands,
and Candles



QolorFLEX®
PROFESSIONAL LED LIGHTING

Key Features

- Ideal for props and costumes with a low profile
- Supports ANSI E1.11 DMX512-A
- Compatible with all Multiverse and SHoW DMX transmitters
- Low profile latch connections for power, dimmer outputs, and DMX out
- Output port test buttons
- Configuration set via RDM
- Built-in short circuit, reverse polarity, and over temperature protection

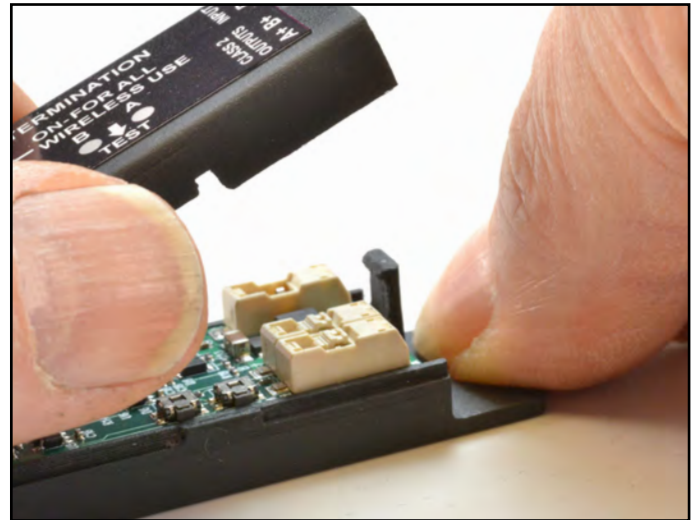

QolorFLEX 5x2.5A Multiverse Dimmer

P/N	Frequency	Universes
5942	900MHz/2.4GHz	1
5943	2.4GHz	1



QolorFLEX® 5x2.5A Multiverse® Dimmers are constant voltage, five-output dimmers that can be controlled wirelessly using City Theatrical's Multiverse wireless DMX/RDM technology, or legacy or SHoW DMX Neo or with wired DMX.

Each dimmer provides 20-bit PWM resolution and extremely smooth dimming at the low end of the dimming curve, with six DMX personality options, including:

- 8-bit (5ch)
- 16-bit (10ch)
- 8-bit Tunable White Single (2ch)
- 16-bit Tunable White Single (4ch)
- 8-bit Tunable White (4ch)
- 16-bit Tunable White (8ch)

These dimmers use detachable input and output connectors to make wiring easy. Configuration is performed using RDM, such as with a City Theatrical DMXcat®, or with City Theatrical's USB Configuration program for PC/Mac.

A mounting bracket is included with each dimmer to allow easy mounting to scenery. These dimmers pair perfectly with QolorFLEX 5-in-1 LED Tape for ideal use in props and costumes, or for areas where space is a concern. QolorFLEX 5x2.5A Multiverse Dimmers are designed and built in the USA by City Theatrical.

Constant Voltage,
Five-output, Wireless
DMX/RDM Dimming



QolorFLEX®
PROFESSIONAL LED LIGHTING

Key Features

- Wireless or wired DMX input
- Wired DMX output
- Mounting bracket included
- Compatible with all Multiverse and SHoW DMX Neo SHoW IDs
- User selectable choice of 2.4GHz or 900MHz radio (P/N 5942 only)
- DMX termination selector switch
- Per channel level indicator lights
- Per channel PWM frequency, response time, and curve selections
- Per channel bump buttons, with disable function
- Per channel offsets to balance the point at which each dimmer first turns on (important for perfect low end balance)
- DMX data loss options
- Micro USB port for firmware updates and configuration
- Class 2 outputs
- Error detection and signal light for short circuits, over current, over/under voltage, over temperature



QolorPIX® Tape Controller, Eight Output for QolorPIX Pixel Controlled LED Tape

P/N	Frequency	Universes
5850	2.4GHz	1



QolorPIX Tape Controller is preconfigured with personality profiles that can be combined and adjusted to produce thousands of dynamic effects with QolorPIX Pixel Controlled LED Tape using only a few DMX channels. Any lighting effect you can imagine - chases, fades, scrolls, bursts, and more - can be created in minutes. The QolorPIX Tape Controller offers eight ports, which accommodate a total of 40 meters of QolorPIX Pixel Controlled LED Tape. The controller features an integrated power supply, a test function and flicker finder for easy troubleshooting. The QolorPIX Tape Controller offers wireless DMX control using Multiverse technology on the 2.4GHz band.

Plug and Play Pixel Effects Controlled by Wireless DMX



Key Features

- Supports ANSI E1.11 DMX512-A
- Eight output ports control individual pixels on each port
- Firmware is user updateable through micro-SD card slot
- Controllable via DMX512-A, recordable presets, and test routine
- DMX512 control through effects engine, RGB, and pixel address modes

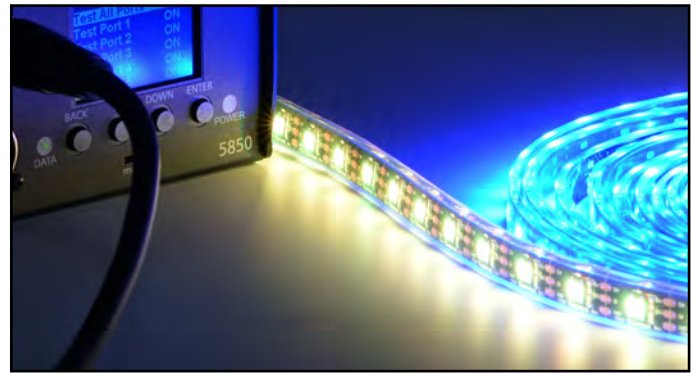

QolorPoint® Wireless LED Uplighter

P/N	Frequency	Universes
7000	2.4GHz	1



High Quality Wireless LED Event Lighting



QolorPoint® Wireless LED Uplighters are bright output, all weather uplighters that help lighting professionals create stunning, high quality lighting effects for indoor and outdoor events.

These easy to use, battery-operated QolorPoint Uplighters now come with onboard Multiverse® wireless DMX/RDM technology equipped as standard, for scalability of wireless DMX lighting data like never before.

Key Features

- Recharge in under five hours
- Built-in Multiverse wireless DMX 2.4GHz Receiver

Wireless DMX Accessories



	P/N	NAME	FOR PRODUCT
STANDARD ANTENNAS: 	5729	2dBi Indoor Omni Antenna, 2.3"	All SHoW Baby models
	5731	4dBi Indoor Omni	Legacy SHoW DMX Neo Transmitter and Receiver
	5980	2dBi/4dBi Omni Broadband Antenna, 900MHz/2.4GHz, Dual Band	Multiverse Module, Multiverse Node, and Multiverse Transmitter
	5983	2.5dBi/2.5dBi Omni Broadband Antenna, 900MHz/2.4GHz, Dual Band Outdoor	Multiverse Vero Transceiver
	5984	1.8dBi/3.8dBi Omni Broadband Antenna, 900MHz/2.4GHz, Dual Band Stubby	Multiverse Studio Receiver
LONG RANGE ANTENNAS: 	5981	Panel, Dual Band 900MHz - 2.4GHz (See City Theatrical website for adapter cables needed.)	Multiverse Node and Multiverse Transmitter
	5982	Yagi, Dual Band 900MHz - 2.4 GHz (See City Theatrical website for adapter cables needed.)	Multiverse Node and Multiverse Transmitter
ACCESSORIES: 	5637	Splitter	All Panel and Yagi antennas
	5638	Adapter Cable	Panel and Yagi to SHoW Baby, Multiverse Node, and Multiverse Transmitter
	5639	Gender Changer for 5637 Splitter	Two needed for each Splitter (P/N 5637)
	5641	Antenna Adapter Cable, N (M) to (N) M, 36"	Multiverse Vero Transceiver and legacy SHoW DMX Vero and Vero Net products
POWER SUPPLIES: 	5627	SHoW DMX Power Supply	SHoW Baby, SHoW DMX Transmitter and Receiver
	5972	Power Supply, 12V, 6W, 5.5x2.1mm, Locking	Multiverse Node and Multiverse Transmitter
HANGING BRACKETS: 	5602	SHoW DMX Mounting Plate (not shown)	SHoW DMX Transmitter and Receiver
	5780	SHoW Baby Hanging Bracket	All SHoW Baby models
	5971	Multiverse Node Hanging Bracket	Multiverse Node
	5974	Multiverse Transmitter Hanging Bracket	Multiverse Transmitter
POWER CORDS: 	5973	Multiverse Node USB Power Cable	Multiverse Node
	5840	N5-15P to powerCON TRUE1, 12AWG, 8'	Multiverse Transmitter
	103-00730	Cable, Coax U.FL(L10-iPEX) to RP-SMA Jack 5", OD1.37mm	Multiverse Module and Multiverse Receiver Card
CONNECTORS: 	5970	Multiverse Locking Barrel Connector Lead, 6"	Multiverse Node

Multiverse Receiver / Transmitter Specifications



	Multiverse Receiver Card	Multiverse SHoW Baby	Multiverse Node
Part Number	5906 (2.4GHz), 5907 (900MHz*)	5900 (2.4GHz)	5902 (900MHz*/2.4GHz), 5903 (2.4GHz)
Applications	Indoor	Indoor	Indoor
Broadcast Power	2.5mW, 8mW, 25mW, 80mW	2.5mW, 8mW, 25mW, 80mW	3.2mW, 10mW, 32mW, 100mW
Antenna(s)	External U.fl connector or Internal	2dBi omni	Omni broadband, 900MHz/2.4GHz, 2dBi/4dBi
User Interface	DMXcat app or USB Configurator	One Button / Indicator Lights	4 Button / Backlit LED Display
Broadcast Modes	Adaptive, Full, Low, Mid, High, Max	Adaptive, Full, Low, Mid, High, Max	Adaptive, Full, Low, Mid, High, Max
Ethernet Protocols	N/A	N/A	N/A
Hopping Patterns	10	10	10
Show IDs	217 (P/N 5906); 90 (P/N 5907)	217	307 (P/N 5902); 217 (P/N 5903)
Latency	4ms average	4ms average	4ms average
RF Sensitivity	-95dBm	-95dBm	-95dBm
RDM Features	RDM Proxy, RDM Responder	RDM Proxy, RDM Responder	RDM Proxy, RDM Responder
Compliance	Pre compliance reports available for integrators	FCC, IC, CE, ARIB, RoHS	5902: FCC, IC 5903: FCC, IC, CE, ACMA, ARIB, RoHS
Power Input	5-30VDC, 0.44W	7.5-30VDC, 1W	5-30VDC, 1W
Power Connector	20-Pin 2x10 0.100-inch header, male	5.5mm x 2.1mm, center positive, 9mm mating depth	Locking DC Jack, 5.5mm x 2.1mm, center positive, 12.1mm mating depth
IP Rating	N/A	IP50	IP50
Construction	PCB Assembly	Injection Molded Plastic	Die Cast Aluminum
Dimensions (L x W x H)	2.0" x 1.5" x 0.25" (50 x 38 x 6.4mm)	3.625" x 3.0" x 1.8" (92 x 76 x 46mm)	4.05" x 2.36" x 1.44" (102.8 x 60 x 36.47mm)

Multiverse technology is covered by U.S. Patents #7,432,803 B2, #10,129,964 B1, and other patents pending.

See product manuals for complete specifications. Specifications may be subject to change.



	Multiverse Vero Transceiver	Multiverse Studio Receiver	Multiverse Transmitter
Part Number	7400-5902 (900MHz*/2.4GHz), 7400-5903 (2.4GHz)	5904 (900MHz*/2.4GHz), 5905 (2.4GHz)	5910 (900MHz*/2.4GHz), 5911 (2.4GHz (x2)), 5912 (900MHz* (x2))
Applications	Outdoor	Indoor, Outdoor (Splashproof)	Indoor
Broadcast Power	3.2mW, 10mW, 32mW, 100mW EIRP	3.2mW, 10mW, 32mW, 100mW EIRP	3.2mW, 10mW, 32mW, 100mW
Antenna(s)	Dual band 900MHz / 2.4GHz 2.5dBi / 2.5dBi Outdoor	Dual band 900MHz / 2.4GHz 1.8dBi / 3.8dBi Stubby	Omni broadband, 900MHz/2.4GHz, 2dBi/4dBi
User Interface	Internal Backlit LCD display	4 Button / Backlit LED Display	DMXcat app
Broadcast Modes	Adaptive, Full, Low, Mid, High, Max	Adaptive, Full, Low, Mid, High, Max	Adaptive, Full, Low, Mid, High, Max
Ethernet Protocols	N/A	N/A	802.11 bgn, 100 BASE-T sACN, Art-Net
Hopping Patterns	10	10	10
Show IDs	307 (P/N 7400-5902); 217 (P/N 7400-5903)	307 (P/N 5904); 217 (P/N 5905)	237 (P/N 5910); 147 (P/N 5911); 90 (P/N 5912)
Latency	4ms average	4ms average	4ms average
RF Sensitivity	-95dBm	-95dBm	-95dBm
RDM Features	RDM Proxy, RDM Responder	RDM Proxy, RDM Responder	RDM Proxy, RDM Responder
Compliance	7400-5902: FCC, IC, cETLus Listed 7400-5903: FCC, IC, CE, UKCA, ARIB, cETLus Listed, RoHS	5904: FCC, IC 5905: FCC, IC, CE, UKCA, ARIB, RoHS	5910/5912: FCC, IC, ETL 5911: FCC, IC, CE, ACMA, ARIB, cETLus Listed, RoHS, EAC
Power Input	90-277VAC input, 1A max	Internal battery; included external power supply 100- 240VAC input, 5VDC output	100-240VAC 50/60Hz, 5-30VDC, POE Class 0, 5W
Power Connector	3 pin screw terminals	USB-C connector	Locking DC Jack, 5.5mm x 2.1mm, center positive, 12.1mm mating depth; powerCON TRUE1 in/thru; EtherCON
IP Rating	IP66	IP61	IP50
Construction	NEMA 4 / IP66 Aluminum enclosure	ABS Plastic	Die Cast Aluminum
Dimensions (L x W x H)	6.5" x 6.0" x 4.0" (165 x 152 x 102mm)	5.5" x 1.812" x 1.0" (139.7 x 46 x 25.4mm)	7.75" x 4.0" x 1.85" (196.9 x 101.5 x 47mm)

*900MHz band is licensed for use in North America only.

Antenna Adapter Selection Matrix

For City Theatrical Wireless DMX Products

	Standard Antennas:				Long Range Antennas:		Accessories:	Legacy Antennas:	
P/N:	5729	5980	5983	5984	5981	5982	5637	5731	5732
Gain (dBi):	2dBi	2dBi/4dBi	2.5dBi/2.5dBi	1.8dBi/3.8dBi	6.8dBi/8.5dBi	11dBi	Antenna Splitter, 3 N-Connectors (Female)	4dBi	4.5dBi
Frequency:	2.4GHz	900MHz/2.4GHz	900MHz/2.4GHz	900MHz/2.4GHz	900MHz/2.4GHz	900MHz/2.4GHz		2.4GHz	2.4GHz
Product Name:	Antenna, Indoor Omni, 2.3"	Antenna, Omni Broadband	Antenna, Omni Broadband	Antenna, Omni Broadband "Stubby"	Antenna, Panel	Antenna, Yagi		Antenna, Indoor Omni (Legacy)	Antenna, Outdoor Omni (Legacy)

Multiverse Wireless DMX Products:

5900 Multiverse® SHoW Baby	Standard; no adapter needed.						
5902 Multiverse Node 900MHz/2.4GHz							
5903 Multiverse Node 2.4GHz							
5910 Multiverse Transmitter 900MHz/2.4GHz		Standard; no adapter needed.					
5911 Multiverse Transmitter 2.4GHz							
5912 Multiverse Transmitter 900MHz							
5904 Multiverse Studio Receiver 900MHz/2.4GHz				Standard; no adapter needed.			
5905 Multiverse Studio Receiver 2.4GHz							
5906 Multiverse Receiver Card 2.4GHz w/ Internal Antenna	Requires the 103-00730 Cable		Requires the 103-00730 Cable and 5638 Adapter Cable	Requires the 103-00730 Cable	Requires the 103-00730 Cable and 5638 Adapter Cable		Requires the 103-00730 Cable, 5938 Adapter Cable, and 5641 Antenna Adapter Cable
5907 Multiverse Receiver Card 900MHz w/ Internal Antenna		Requires the 103-00730 Cable					
7400-5902 Multiverse Vero Transceiver 900MHz/2.4GHz					Requires 5641 Adaptor Cable N-Male to N-Male		Requires three 5641 Adaptor Cables: N-Male to N-Male
7400-5903 Multiverse Vero Transceiver 2.4GHz			Standard; no adapter needed.				

Legacy Wireless DMX Products:

5702M SHoW DMX SHoW Baby® 6 (Legacy)	Standard; no adapter needed.						
5701 SHoW DMX Neo® Transmitter (Legacy)					Requires 5638 Adapter Cable RSMA-Male to N-Male		
5711 SHoW DMX Neo Receiver (Legacy)						Requires two 5641 Adaptor Cables, N-Male to N-Male, and one 5638 Adapter Cable RSMA-Male to N-Male	Standard; no adapter needed.
7400-5707 SHoW DMX Vero® (Legacy)					Requires 5641 Adaptor Cable N-Male to N-Male		Requires three 5641 Adaptor Cables N-Male to N-Male
7400-5708 SHoW DMX Vero Net (Legacy)							Standard; no adapter needed.

Instructions:

- Select a device from the left column.
- The row for that device will indicate which adapters are necessary to use each antenna/adaptor listed in the top row.
- If the cell is gray, that antenna will not work with your selected device.

Reference:



CITY
THEATRICAL
 NEW YORK • LONDON

475 BARELL AVENUE, CARLSTADT, NJ 07072
 800.230.9497 OR 201.549.1160
 201.549.1161 FAX

OFFICE 31, UNITS 1-3, BEVERLY WAY, NEW MALDEN,
 KT3 4PH UNITED KINGDOM
 +44 (0) 20 8949 5051